



INSTRUCTIONS FOR:

3tonne TROLLEY JACK WITH SAFETY LOCK

MODEL No: **3000LJ.V2**

Thank you for purchasing a Sealey product. Manufactured to a high standard, this product will, if used according to these instructions, and properly maintained, give you years of trouble free performance.

IMPORTANT: PLEASE READ THESE INSTRUCTIONS CAREFULLY. NOTE THE SAFE OPERATIONAL REQUIREMENTS, WARNINGS & CAUTIONS. USE THE PRODUCT CORRECTLY AND WITH CARE FOR THE PURPOSE FOR WHICH IT IS INTENDED. FAILURE TO DO SO MAY CAUSE DAMAGE AND/OR PERSONAL INJURY AND WILL INVALIDATE THE WARRANTY. KEEP THESE INSTRUCTIONS SAFE FOR FUTURE USE.



Refer to instruction manual

1. SAFETY

- ✓ Ensure the jack is in sound condition and good working order. Take action for immediate repair or replacement of damaged parts.
Use genuine parts only. The use of non genuine parts may be dangerous and will invalidate the warranty.
- ✓ Locate the jack in a suitable, well lit working area. Keep working area clean and tidy and free from unrelated materials.
- ✓ Use jack on level and solid ground, preferably concrete. *Avoid tarmacadam as the jack may sink in.*
- ✓ Place wedges under wheels of vehicle, but ensure the jack wheels are free to move and that there are no obstructions.
- ✓ Ensure the vehicle handbrake is engaged, engine is switched off and transmission is in gear (or "PARK" if automatic).
- ✓ Ensure minimum distance of 0.5m between the vehicle and static objects such as doors, walls, etc., to allow for vehicle tilting.
- ✓ Ensure there are no passengers in the vehicle and that all non-essential persons keep a safe distance whilst the jack is in use.
- ✓ Place the jack under lifting points recommended by the vehicle manufacturer (*see vehicle hand book*). Ensure lifting point is stable and centred on the saddle.
- ☐ **DANGER:** *Use the jack for lifting only, NOT for supporting the lifted load.*
- ✓ Use suitable capacity axle stands under the vehicle before proceeding with any task.
- ✓ Ensure there are no persons or obstructions beneath the vehicle before lowering.
- x **DO NOT** operate the jack if damaged.
- x **DO NOT** work under the vehicle until axle stands have been correctly positioned.
- x **DO NOT** exceed the rated capacity of the jack and **DO NOT** adjust the safety overload valve.
- x **DO NOT** jack the vehicle if there is a risk of spillage of fuel, battery acid, or other dangerous substances.
- x **DO NOT** allow the vehicle to move while supported by the jack, or use the jack to move the vehicle.
- x **DO NOT** top up the hydraulic system with brake fluid. Use hydraulic jack oil only and use a qualified person to maintain jack hydraulic system.
- x **DO NOT** allow untrained persons to operate the jack and **DO NOT** use jack for purposes other than for which it is designed.
- x **DO NOT** allow persons to ride on the jack.
- ✓ When not in use store the jack, fully lowered, in a safe, dry, childproof area.

2. INTRODUCTION

Steel framed 3tonne locking jacks with a three position safety locking mechanism that provides additional load security and hydraulic system fail safe. Automatic bypass prevents jack damage from over pumping. For safety reasons always use in conjunction with axle stands in pairs.

3. SPECIFICATION

Model No:	3000LJ
Capacity	3Tonne
Locking Position 1:	325mm
Locking Position 2:	405mm
Locking Position 3:	470mm
Min. saddle height	145mm
Max. saddle height	505mm
Max. chassis height	190mm
Length	690mm
Weight	37kg



4. OPERATION

4.1. Before first use.

- 4.1.1. Bolt the two sections of the handle (fig.1.A.) together, place the lower end over the square section of the release valve spindle and secure with the retaining bolt (fig.1.B)
- 4.1.2. Before using the jack for the first time, purge the hydraulic unit in order to eliminate any air in the system. Turn the release valve (fig.2.A) anticlockwise and pump about 20 strokes. Close the release valve by turning clockwise.
- 4.1.3. Check the oil level and top up if necessary. To do this, remove the cover plate by removing the four retaining screws. Remove the oil filler plug (fig.1.C) with an 8mm hex key. The oil should be level with the bottom of the filler port. Top up if necessary with a good quality jack oil, such as Sealey Hydraulic Jack Oil. Replace the filler plug.
- 4.1.4. Place a few drops of hydraulic jack oil on the pump piston and pump handle several times to distribute oil, then replace the cover plate. Lubricate moving parts thoroughly.

4.2. General jacking.

WARNING! Before lifting ensure Section 1 'Safety Precautions' is read and understood.

- 4.2.1. Prepare the vehicle as mentioned in the safety precautions ensuring the ground on which the jack is to stand is level and solid (not tarmacadam).
- 4.2.2. Position the jack saddle under the vehicle manufacturer's recommended lifting point.

4.3. Jacking the vehicle.

- 4.3.1. Ensure that the release valve is closed and commence pumping the handle up and down, using full strokes, until the jack saddle reaches the vehicle jacking point. Check that the jacking point is centrally located on the saddle and raise the vehicle.
- 4.3.2. As the jack lifts, the locking bar will be heard to drop into the locking track at three points during the jack's travel. In the unlikely event of an hydraulic failure, the lifting arm will only fall back to the previous locking point.
- 4.3.3. Should the jack become overloaded, a safety excess pressure valve will open, and stop the jack from lifting.

WARNING! The jack is a lifting device only and must not be used to support the load. Use correctly rated axle stands to support the load.

4.4. Lowering the vehicle.

- 4.4.1. If using axle stands, raise the jack high enough for the stands to be removed easily. Place one foot on the safety release pedal (fig.2.B.). If the pedal will not depress easily, pump the jack up slowly until it releases.
 - 4.4.2. Keep the pedal depressed and turn the release valve anticlockwise
 - 4.4.3. The lowering speed is controlled by the amount you turn the handle. Lower carefully, avoid any sudden changes in descent rate which would shock load the hydraulic system.
- WARNING!** Ensure there are no persons or obstacles beneath the vehicle, or in the path of its descent.

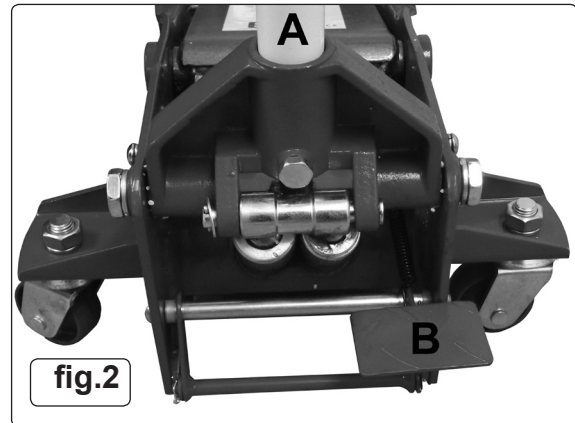
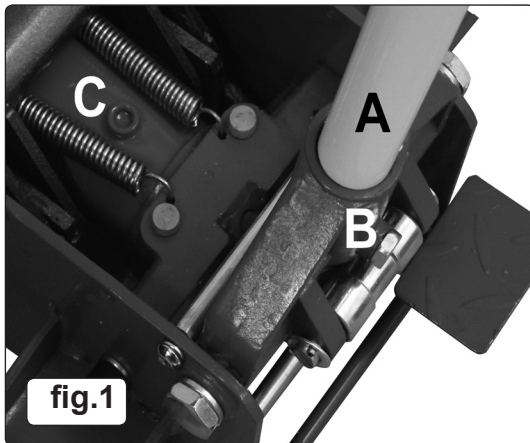

5. MAINTENANCE

- 5.1. When the jack is not in use, the ram should be in its lowest position to minimise corrosion. Remove the handle to deactivate the jack.
- 5.2. Keep the jack clean and lubricate all moving parts with oil on a regular basis.
- 5.3. Before each use check for broken, cracked, bent, or loose parts, or any visible damage to ram, pump, saddle, lifting arm, frame and all parts including nuts, bolts, pins and other fasteners. If any suspect item is found remove the jack from service and take necessary action to remedy the problem.
DO NOT use the jack if believed to have been subjected to abnormal load or shock load.
- 5.4. Check the pump piston and the ram periodically for signs of corrosion. Clean exposed areas with a clean oiled cloth.
- 5.5. After one year the oil should be replaced in order to extend the life of the jack. Use hydraulic jack oil only.
- ✓ **IMPORTANT:** Only fully qualified personnel should attempt hydraulic maintenance or repair.
- 5.6. To check the oil level, refer to section 3.1.3.
- WARNING: DO NOT** use brake fluid, or any fluid other than hydraulic jack oil as this may cause serious damage to the jack and will invalidate the warranty!
- 5.7. To drain the oil, remove the filler plug and raise front of jack. Make sure that no dirt is allowed to enter the hydraulic system.

✓ **IMPORTANT: NO RESPONSIBILITY IS ACCEPTED FOR INCORRECT USE OF THIS PRODUCT.**

Hydraulic products are only repaired by local service agents. We have service/repair agents in all parts of the UK.

DO NOT RETURN JACKS TO US. Please telephone us on 01284 757500 to obtain the address and 'phone number of your local agent.

If jack is under guarantee contact your local Sealey dealer.

De-commissioning the Jack

Should the jack become completely unserviceable and require disposal, draw off the oil into an approved container and dispose of the jack and the oil according to local regulations.

6. TROUBLE SHOOTING

IMPORTANT: MAINTENANCE OR REPAIR OF HYDRAULIC SYSTEM MUST ONLY BE PERFORMED BY A QUALIFIED PERSON.

PROBLEM	POSSIBLE CAUSE	REMEDY
Jack will not lift the load	<ol style="list-style-type: none"> 1) Overloaded 2) Oil level low 3) Release valve not correctly closed 4) Air in system 5) Piston rod not functioning 6) Packing worn or defective 	<ol style="list-style-type: none"> 1) Be sure to use jack with adequate capacity 2) Top up oil level 3) Check and close release valve 4) Open release valve and pump the handle a few times. Close valve and re-try 5) Clean and replace oil 6) Replace packing
Jack does not lift high enough or feels "spongy"	<ol style="list-style-type: none"> 1) Oil level too high or too low 2) Worn seals 3) Air in system 4) Release valve not closed 	<ol style="list-style-type: none"> 1) Fill or remove excess oil 2) Return jack to local service agent 3) Open release valve and pump the handle a few times. Close valve and re-try 4) Check and close release valve
Jack lifts poorly	<ol style="list-style-type: none"> 1) Pump packing or valves malfunctioning 2) Oil is dirty 3) Air in the system 	<ol style="list-style-type: none"> 1) Replace packing and/or clean valves 2) Replace oil 3) Open release valve and pump the handle a few times. Close valve and re-try
Jack lifts but will not hold load	<ol style="list-style-type: none"> 1) Release valve partially open 2) Dirt on valve seats 3) Air in system 4) Faulty seals 5) Packing worn or defective 	<ol style="list-style-type: none"> 1) Check and close release valve 2) Lower jack, close release valve. Place foot on front wheel and pull up lifting arm to it's full height by hand. Open the release valve to lower arm 3) Open release valve and pump the handle a few times. Close valve and re-try 4) Replace packing or contact local service agent 5) Replace packing
Jack will not lower completely	<ol style="list-style-type: none"> 1) Unit requires lubrication 2) Piston rod bent or damaged 3) Jack frame/link system distorted due to overloading/poor positioning 4) Air in system 5) Release valve partially closed 6) Jack spring damaged or unhooked. 7) Safety lock engaged 	<ol style="list-style-type: none"> 1) Oil all external moving parts 2) Replace rod or contact local service agent 3) Replace damaged parts or contact local service agent 4) Open release valve and pump the handle a few times. Close valve and re-try 5) Check and fully open release valve 6) Replace spring or contact local service agent 7) Pump clear of lock and press release pedal.
Jack does not lower at all	<ol style="list-style-type: none"> 1) Release valve closed 2) Safety lock engaged 	<ol style="list-style-type: none"> 1) Check and fully open release valve. 2) Pump clear of lock and press release pedal.

Environmental Protection



Recycle unwanted materials instead of disposing of them as waste. All tools, accessories and packaging should be sorted, taken to a recycling centre and disposed of in a manner which is compatible with the environment. When the product becomes completely unserviceable and requires disposal, drain off any fluids (if applicable) into approved containers and dispose of the product and the fluids according to local regulations.

Parts support is available for this product. To obtain a parts listing and/or diagram, please log on to www.sealey.co.uk, email sales@sealey.co.uk or telephone 01284 757500.

NOTE: It is our policy to continually improve products and as such we reserve the right to alter data, specifications and component parts without prior notice.

IMPORTANT: No liability is accepted for incorrect use of this product.

WARRANTY: Guarantee is 12 months from purchase date, proof of which will be required for any claim.



Sole UK Distributor, Sealey Group,
Kempson Way, Suffolk Business Park,
Bury St. Edmunds, Suffolk,
IP32 7AR



01284 757500



01284 703534



www.sealey.co.uk



sales@sealey.co.uk