

Thank you for purchasing a Sealey product. Manufactured to a high standard this product will, if used according to these instructions and properly maintained, give you years of trouble free performance.

IMPORTANT: READ THESE INSTRUCTIONS CAREFULLY. NOTE THE SAFE OPERATIONAL REQUIREMENTS, WARNINGS AND CAUTIONS. USE THIS JACK CORRECTLY AND WITH CARE FOR THE PURPOSE FOR WHICH IT IS INTENDED. FAILURE TO DO SO MAY CAUSE DAMAGE AND/OR PERSONAL INJURY AND WILL INVALIDATE THE WARRANTY. RETAIN THESE INSTRUCTIONS FOR FUTURE USE.

1. SAFETY PRECAUTIONS

- ✓ Ensure the jack is in sound condition and good working order. Take action for immediate repair or replacement of damaged parts.
 Use *genuine parts only*. The use of *unauthorised parts may be dangerous and will invalidate the warranty*.
- ✓ Locate the jack in a suitable, well lit working area.
- ✓ Keep working area clean and tidy and free from unrelated materials.
- ✓ Use jack on level and solid ground, preferably concrete. *Avoid tarmac as jack may sink in.*
- ✓ Place wedges under wheels of vehicle (*but ensure wheels of jack can move freely*).
- ✓ Ensure the vehicle handbrake is engaged, engine is switched off and transmission is in 1st or reverse gear (or "PARK" if automatic).
- ✓ Ensure minimum distance of 0.5m between vehicle and static objects such as doors, walls, etc., to allow for vehicle tilting.
- ✓ Ensure there are no passengers in the vehicle.
- ✓ Ensure all non-essential persons keep a safe distance whilst the jack is in use.
- ✓ Only place jack under those lifting points recommended by vehicle manufacturer (*see vehicle hand book*).
- ✓ Check the lifting point is stable and centred on the jack saddle.
- ✓ Ensure the jack wheels are free to move and that there are no obstructions.
- ☐ **DANGER:** Use the jack for lifting only, NOT for supporting the lifted load.
- ✓ Once the vehicle is raised use suitable capacity axle stands before proceeding with any task.
- ✓ Ensure there are no persons or obstructions beneath the vehicle before lowering.
- ✓ Use a qualified person to maintain or repair the jack hydraulic system.
- ✗ **DO NOT** operate the jack if damaged.
- ✗ **DO NOT** allow untrained persons to operate the jack.
- ✗ **DO NOT** exceed the rated capacity of the jack.
- ✗ **DO NOT** allow the vehicle to move while supported by the jack, nor use the jack to move the vehicle.
- ✗ **DO NOT** jack vehicle if there is a risk of spillage of fuel, battery acid, or other dangerous substance.
- ✗ **DO NOT** work under the vehicle until axle stands have been correctly positioned.
- ✗ **DO NOT** use the jack for purposes other than that for which it is designed.
- ✗ **DO NOT** top up hydraulic system with brake fluid. Use hydraulic jack oil only.
- ✗ **DO NOT** adjust the safety overload valve.
- ✓ When not in use store jack, fully lowered, in a safe, dry, childproof area.

2. SPECIFICATION

Capacity 2 ton	Max. Chassis Height 192mm
Min. Saddle Height 140mm	Length. 1185mm
Max. Saddle Height 800mm	Weight 55kg

3. ASSEMBLY & PURGING

Note: Numbers in brackets refer to item numbers in the Parts List.

- 3.1. **Handle:** Loosen location bolt on the handle socket. Place the handle into the socket and press it home. Retighten the location bolt with spring washer and nut (fig.1a).
Foot Pedal: Remove locating bolt on foot pedal casting (fig.1b), place foot pedal into gap and slide the bolt through the casting and pedal, secure with spring washers and nut (see fig.1).
- 3.2. Before using the jack for the first time, purge hydraulic circuit in order to eliminate any air in the system. To do so turn the valve control knob (fig.2) anti-clockwise to open the release valve. Pump the handle or foot pedal 15 to 20 times. At the end of the last downward stroke shut the valve off again by turning the control knob clockwise.
- 3.3. Place a few drops of hydraulic jack oil on the pump piston and pump the handle several times to distribute the oil. Thoroughly lubricate all moving parts.

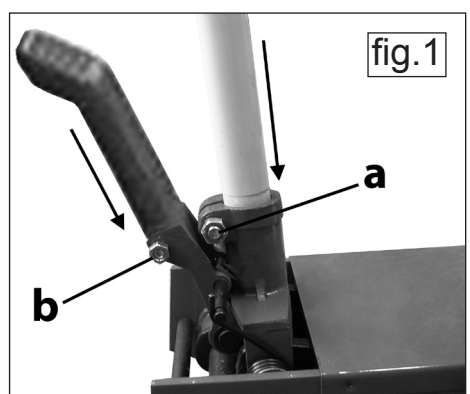

4. OPERATING INSTRUCTIONS

- 4.1. **General jacking.** ☐ **WARNING!** Before lifting, ensure Section 1 safety instructions are strictly followed.
- 4.2. Prepare vehicle as described in safety instructions ensuring the ground on which jack is to stand is level and solid (not tarmac).
- 4.3. Position the jack saddle under the vehicle manufacturer's recommended lifting point (see vehicle handbook).
- 4.4. **Jacking the vehicle.** Ensure the release valve is closed (i.e. the control knob is turned fully clockwise). Commence pumping the handle/foot pedal up and down using maximum strokes until the vehicle reaches the working height.
- 4.5. Should the jack become overloaded, the safety valve will open, and stop the jack from lifting.
- 4.6. **Lowering the vehicle.** Turn the control knob anti-clockwise to open the valve and lower the load.
- 4.7. The lowering speed is controlled by the amount you turn the knob. Lower slowly and carefully, avoiding sudden release.

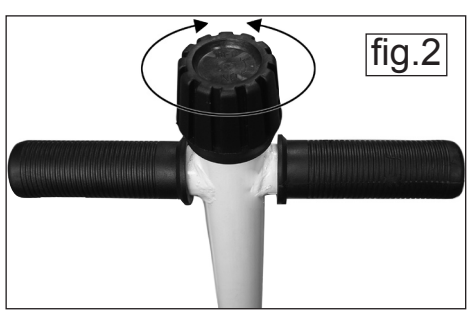

5. MAINTENANCE

IMPORTANT: Only fully qualified personnel should attempt maintenance or repair.

- 5.1. When the Jack is not in use, the ram and the handle socket should be in their lowest position to minimise corrosion. Remove the handle to inactivate Jack.
- 5.2. Keep the Jack clean and lubricate all moving parts with a suitable oil on a regular basis.
- 5.3. To check the oil level, fully lower the Jack. Remove filler plug (fig.3a). The correct oil level should be approximately 5mm below the filler opening. If oil level is low, fill as required. Pump unloaded jack 15 to 20 times to expel air and then refit plug.

NOTE: Use a good quality jack oil, such as SEALEY HYDRAULIC JACK OIL.

- WARNING:** DO NOT use brake fluid, or any fluid other than hydraulic jack fluid as this may cause serious damage to the Jack and will invalidate the warranty!
- 5.4. Before each use check for broken, cracked, bent, or loose parts, or any visible damage to welds, ram, pump, saddle, lifting arm, frame and all parts including nuts, bolts, pins and other fasteners. If any suspect item is found remove jack from service and take necessary action to remedy the problem. **DO NOT** use the jack if believed to have been subjected to abnormal load or shock. Inspect and take appropriate action.
 - 5.5. Every three months remove the locking rings on the caster wheels and lubricate the ball bearings with acid free grease.
 - 5.6. After a year of extensive use, the oil should be replaced in order to extend the life of your jack. To drain the oil, remove the filler cap and valve. Make sure that no dirt is allowed to enter the hydraulic system's oil. Dispose of oil according to local authority regulations. See 5.3. for refill instructions.
 - 5.7. Periodically check the pump piston and piston rod for signs of corrosion. Clean exposed areas with a clean oiled cloth.

IMPORTANT: NO RESPONSIBILITY IS ACCEPTED FOR INCORRECT USE OF THE JACK.

Hydraulic products are only repaired by local service agents. We have service/repair agents in all parts of the UK.

DO NOT RETURN JACKS TO US. Please telephone us on 01284 757500 to obtain the address and phone number of your local agent. If Jack is under guarantee please contact your dealer.

De-commissioning the Jack

Should the Jack become completely unserviceable and require disposal, draw off the oil into an approved container and dispose of the Jack and the oil according to local regulations.

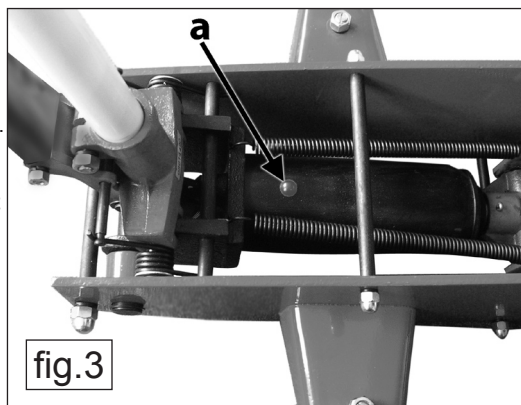

fig.3

6. TROUBLESHOOTING

PROBLEM	POSSIBLE CAUSE	REMEDY
Jack will not lift the load	<ol style="list-style-type: none"> 1) Overloaded 2) Oil level low 3) Release valve not correctly closed 4) Air in system 5) Piston rod not functioning 6) Packing worn or defective 	<ol style="list-style-type: none"> 1) Be sure to use a jack with adequate lifting capacity 2) Top up oil level 3) Check and close release valve 4) Open release valve and pump the handle 15 to 20 times. Close valve and re-try 5) Clean and replace oil 6) Replace packing
Jack does not lift high enough or feels "spongy"	<ol style="list-style-type: none"> 1) Oil level too high or too low 2) Worn seals 3) Air in system 4) Release valve not closed 	<ol style="list-style-type: none"> 1) Fill or remove excess oil 2) Return jack to local service agent 3) Open release valve and pump the handle 15 to 20 times. Close valve and re-try 4) Check and close release valve
Jack lifts poorly	<ol style="list-style-type: none"> 1) Pump packing or valves malfunctioning 2) Oil is dirty 3) Air in the system 	<ol style="list-style-type: none"> 1) Replace packing and/or clean valves 2) Replace oil 3) Open release valve and pump the handle 15 to 20 times. Close valve and re-try
Jack lifts but will not hold load	<ol style="list-style-type: none"> 1) Release valve partially open 2) Dirt on valve seats 3) Air in system 4) Faulty seals 5) Packing worn or defective 	<ol style="list-style-type: none"> 1) Check and close release valve 2) Lower jack, close release valve. Place foot on front wheel and pull up lifting arm to it's full height by hand. Open the release valve to lower arm 3) Open release valve and pump the handle 15 to 20 times. Close valve and re-try 4) Replace packing or contact local service agent 5) Replace packing
Jack will not lower completely	<ol style="list-style-type: none"> 1) Unit requires lubrication 2) Piston rod bent or damaged 3) Jack frame/link system distorted due to overloading/poor positioning 4) Air in system 5) Release valve partially open 6) jack spring damaged 	<ol style="list-style-type: none"> 1) Oil all external moving parts 2) Replace rod or contact local service agent 3) Replace damaged parts or contact local service agent 4) Open release valve and pump the handle 15 to 20 times. Close valve and re-try 5) Check and fully open release valve 6) Replace spring or contact local service agent
Jack does not lower at all	<ol style="list-style-type: none"> 1) Release valve still closed 	<ol style="list-style-type: none"> 1) Check and fully open release valve

Declaration of Conformity We, the sole importer into the UK, declare that the product listed below is in conformity with the following standards and directives.

Trolley Jack
Model 2800HL
 93/68/EEC CE Marking Directive
 2006/42/EC Machinery Directive



The construction file for this product is held by the Manufacturer and may be inspected, by a national authority, upon request to Jack Sealey Ltd.

Signed by Mark Sweetman

10th October 2008

For Jack Sealey Ltd. Sole importer into the UK of Sealey Quality Machinery.

NOTE: It is our policy to continually improve products and as such we reserve the right to alter data, specifications and component parts without prior notice.

IMPORTANT: No liability is accepted for incorrect use of this product.

WARRANTY: Guarantee is 12 months from purchase date, proof of which will be required for any claim.

INFORMATION: For a copy of our latest catalogue and promotions call us on 01284 757525 and leave your full name and address, including postcode.



Sole UK Distributor
Sealey Group,
 Bury St. Edmunds, Suffolk.

01284 757500
 01284 703534

www.sealey.co.uk
 sales@sealey.co.uk