



INSTRUCTIONS FOR

ARC WELDERS

MODEL No's:

150XL.V3

150XTC.V3

160XTC.V3

200XTC.V3

Thank you for purchasing a Sealey Power Welder. Manufactured to a high standard this product will, if used according to these instructions and properly maintained, give you years of trouble free performance.



IMPORTANT: BEFORE USING THIS PRODUCT, PLEASE READ THE INSTRUCTIONS CAREFULLY. NOTE THE SAFE OPERATIONAL REQUIREMENTS, WARNINGS, AND CAUTIONS. USE THIS PRODUCT CORRECTLY, AND WITH CARE FOR THE PURPOSE FOR WHICH IT IS INTENDED. FAILURE TO DO SO MAY CAUSE DAMAGE AND/OR PERSONAL INJURY AND WILL INVALIDATE THE WARRANTY.

INTRODUCTION

This instruction manual contains the information required to prepare your arc welding set for welding. For Individual model specifications refer to part 2. The instructions are not intended to show you how to become a welder. If you have no experience, we recommend that you seek training from an expert source. Arc welding is relatively easy to perform, but does require a steady hand and time practising with scrap metal, as it is only with continued practice that you will achieve the desired results.

1. SAFETY INSTRUCTIONS

1.1. ELECTRICAL SAFETY

WARNING! It is the responsibility of the owner and the operator to read, understand and comply with the following:

You must check all electrical products, before use, to ensure that they are safe. You must inspect power cables, plugs, sockets and any other connectors for wear or damage. You must ensure that the risk of electric shock is minimised by the installation of appropriate safety devices. A Residual Current Circuit Breaker (RCCB) should be incorporated in the main distribution board. We also recommend that a Residual Current Device (RCD) is used. It is particularly important to use an RCD with portable products that are plugged into a supply which is not protected by an RCCB. If in any doubt consult a qualified electrician. You may obtain a Residual Current Device by contacting your Sealey dealer.

You must also read and understand the following instructions concerning electrical safety.

- 1.1.1. The **Electricity at Work Act 1989** requires that all portable electrical appliances, if used on business premises, are tested by a qualified electrician, using a Portable Appliance Tester (PAT), at least once a year.
- 1.1.2. The **Health & Safety at Work Act 1974** makes owners of electrical appliances responsible for the safe condition of those appliances and the safety of the appliance operators. **If in any doubt about electrical safety, contact a qualified electrician.**
- 1.1.3. Ensure that the insulation on all cables and on the appliance is safe before connecting it to the power supply. See 1.1.1. and 1.1.2. and use a Portable Appliance Tester.
- 1.1.4. Ensure that cables are always protected against short circuit and overload.
- 1.1.5. Regularly inspect power supply cables and plugs for wear or damage and check all connections to ensure that none is loose.
- 1.1.6. **Important:** Ensure that the voltage marked on the appliance matches the power supply to be used and that the plug is fitted with the correct fuse - see fuse rating at right.
- 1.1.7. **DO NOT** pull or carry the appliance by the power cable.
- 1.1.8. **DO NOT** pull the plug from the socket by the cable.
- 1.1.9. **DO NOT** use worn or damaged cables, plugs or connectors. Immediately have any faulty item repaired or replaced by a qualified electrician. When a BS 1363/A UK 3 pin plug is damaged, cut the cable just above the plug and **dispose of the plug safely.** Fit a new plug according to the following instructions (UK only).
 - a) **Connect the GREEN/YELLOW earth wire to the earth terminal 'E'.**
 - b) **Connect the BROWN live wire to the live terminal 'L'.**
 - c) **Connect the BLUE neutral wire to the neutral terminal 'N'.**
 - d) **After wiring, check that there are no bare wires, that all wires have been correctly connected, that the cable outer insulation extends beyond the cable restraint and that the restraint is tight.**

Double insulated products, which are always marked with this symbol , are fitted with live (brown) and neutral (blue) wires only. To rewire, connect the wires as indicated above - **DO NOT** connect either wire to the earth terminal.
- 1.1.10. Products which require more than 13 amps are supplied without a plug. In this case you must contact a qualified electrician to ensure that a suitably rated supply is available. We recommend that you discuss the installation of an industrial round pin plug and socket with your electrician.
- 1.1.11. If an extension reel is used it should be fully unwound before connection. A reel with an RCD fitted is preferred since any appliance plugged into it will be protected. The cable core section is important and should be at least 1.5mm², but to be absolutely sure that the capacity of the reel is suitable for this product and for others which may be used in the other output sockets, we recommend the use of 2.5mm² section cable.

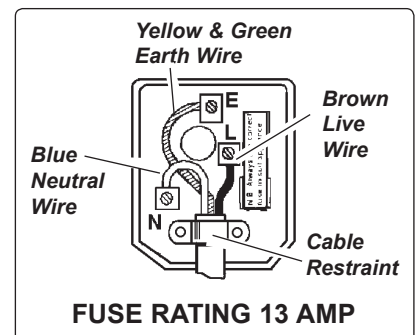

1.2 GENERAL SAFETY **WARNING! Arc welding produces sparks, fused metal projectiles and fumes which are dangerous.**

- WARNING:** Unplug from the mains power supply before performing maintenance or service.
- ✓ Keep the welder and cables in good working order and condition. *Take immediate action to repair or replace damaged parts.*
- ✓ Replace or repair damaged parts. *Use genuine parts only, unauthorised parts may be dangerous and will invalidate the warranty.*
- ✓ Keep the welder clean for best and safest performance.
- ✓ Locate welder in a suitable work area. Ensure area has adequate ventilation as welding fumes are harmful.
- ✓ Keep work area tidy and free from unrelated materials. Also ensure work area has adequate lighting and a fire extinguisher is at hand.
- WARNING:** You **MUST** use an appropriate shaded lens welding face mask (contact your Sealey dealer for details). **DANGER!** Permanent eye damage may result if you do not use correct protection. Also wear safety welding gauntlets and dry, oil free safety protective clothing to protect yourself from sparks and hot droplets of fused metal. Cover exposed flesh to avoid potential burns from the ultraviolet rays of the arc. Use non-reflective welding curtains to protect other people in the area.
- ✓ Check you have good ventilation and that air can flow freely around the welder.
- DANGER!** Ensure no flammable or combustible materials are near work area. Welding containers or pipes which hold, or have held dangerous gases or substances may explode or burn. Materials cleaned with chlorinated solvents, or varnished surfaces pose danger of toxic fumes.

- ✓ Keep unauthorised persons at a safe distance from the work area. Persons within the work area are subject to the same dangers as the welder and must take the same precautions.
- x DO NOT weld on pressurised containers.
- ✓ Remove ties, watches, rings and other jewellery and contain long hair.
- x DO NOT use the welder for any purpose other than that for which it is designed.
- x DO NOT use the welder in damp or wet locations.
- x DO NOT stand welder on a metal workbench, car bodywork or similar object.
- x DO NOT touch any live metal parts of the torch or electrode while the machine is switched on.
- x DO NOT weld without a welding safety head shield, gauntlets, clothing.
- ▲ **DANGER!** DO NOT weld near inflammable materials - solids, liquids, or gases.
- x DO NOT operate welder while under the influence of drugs, alcohol or other medication, or if you are tired.
- x DO NOT operate the welder if it or the cables are damaged.
- x DO NOT allow untrained persons to operate the welder.
- x DO NOT pull welder by the cable, or electrode holder. DO NOT bend or strain cables, protect from sharp or abrasive items. DO NOT stand on cables or leads. Protect from heat. Long lengths of slack must be gathered and neatly coiled. DO NOT place cables where they endanger others.
- x DO NOT touch the electrode holder or workpiece immediately after welding as they will be very hot. Allow to cool.
- x DO NOT open the cover of the machine. Switch off machine and remove the plug from the power supply after use.
- x The electromagnetic fields generated by the welding process may interfere with the operation of electrical and electronic equipment.
- ✓ Users of vital electrical or electronic devices (e.g.pace-makers, respirators etc.) should consult a doctor before entering areas where welding machines are in use.(see Section 8).
- ✓ Users of vital electrical or electronic devices should not use any welding machine.

2. DESCRIPTION & SPECIFICATIONS

HEAVY DUTY AIR-COOLED ARC WELDER

The "XL" model is fitted with a heavy duty air-cooled transformer. Features include single vented wrap-around shell fitted on heavy duty chassis, carrying handle and screw-type stepless welding current control. Supplied with a full accessory kit, including electrode holder, earth clamp hammer/brush,and mask.

	Welding Current	Electrode Capacity	Cooling	Output Cable Ø	No-Load Voltage	Power Input/ Efficiency	Weight
150XL.V3	40-150A	Ø1.6-3.2mm	Air Cooled	10mm ²	48V	230V 1ph 3.35 kVA	20 kg

HEAVY DUTY TURBO COOLED ARC WELDERS

Turbo Forced Air Cooling System, the "XTC" range has increased duty cycle and performance. Featuring single vented wrap-around shells fitted to a heavy duty chassis with wheels and chassis support and a screw-type stepless welding current control. Supplied with carrying handle and extension bar for easy mobility. Complete with full accessory kits including electrode holder, earth clamp chipping hammer,brush and mask.

	Welding Current	Electrode Capacity	Cooling	Output Cable Ø	No-Load Voltage	Power Input/ Efficiency	Weight
150XTC.V3	40-150A	Ø1.6-3.2mm	Turbo Fan	10mm ²	48V	230V 1ph 3.35 kVA	20 kg
160XTC.V3	55-160A	Ø2-4mm	Turbo Fan	16mm ²	49V	230V 1ph 5.98 kVA	21 kg
200XTC.V3	55-200A	Ø2-4mm	Turbo Fan	16mm ²	52V	230V 1ph 5.98 kVA	27 kg

IMPORTANT INFORMATION
To operate all welders to their full capacity, you **must** run them on the correct power supply. To check the amperage, use the following formula: **kVA Rating x 4.35 = Correct Amps Supply**

3. ASSEMBLY

- 3.1. **Assembly:** Separate the main components of the mask as shown in A and B below into their separate parts. Trim any spikes and burrs of excess plastic from the pieces in preparation for assembly.
 - 3.1.1. Overlap the two main halves of the mask so that the fixing holes line up and insert one fixing (1) from the outside into the hole above the window. Place the assembly face downwards.
 - 3.1.2. Lay the tinted glass window (2) over the window opening and lay the frame (3) over the glass. Screw a plastic retainer ring (4) onto fixing (1).
 - 3.1.3. Lift up the assembly and insert the handle threads (7) through the two holes below the window. Turn the assembly over and fix the handle with plastic retaining rings 8 and 9.
 - 3.1.4. Insert fixing (5) through the remaining hole in the top of the mask and fix it with the remaining retaining ring (6).

3.2. **Use:** Always hold mask close to the face to provide maximum protection from radiation and droplets of molten metal.

- 3.2.1. Before each use check that the mask is undamaged and that the filter glass is in position and firmly retained. Remove any metal droplets that may be on the glass. **Danger! Never use a filter glass that is chipped, cracked or otherwise faulty as severe eye damage may result. Warning! Do not allow the mask to come into contact with flame as the fumes produced are harmful.**
- 3.2.3. Clean with soapy water, do not use solvents.

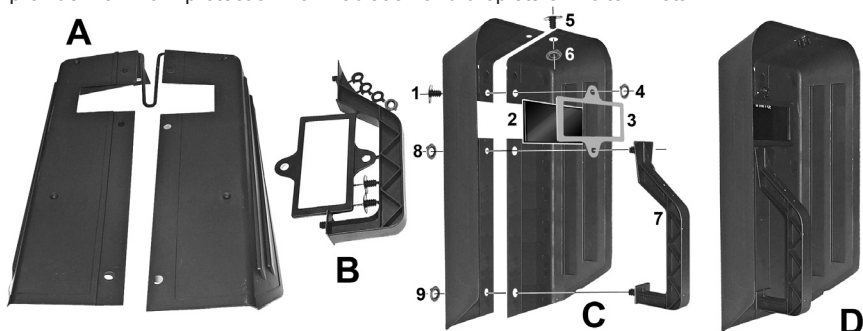

3.3. Where necessary assemble wheels, handle & feet according to the model supplied.(figs 1a,1b,)

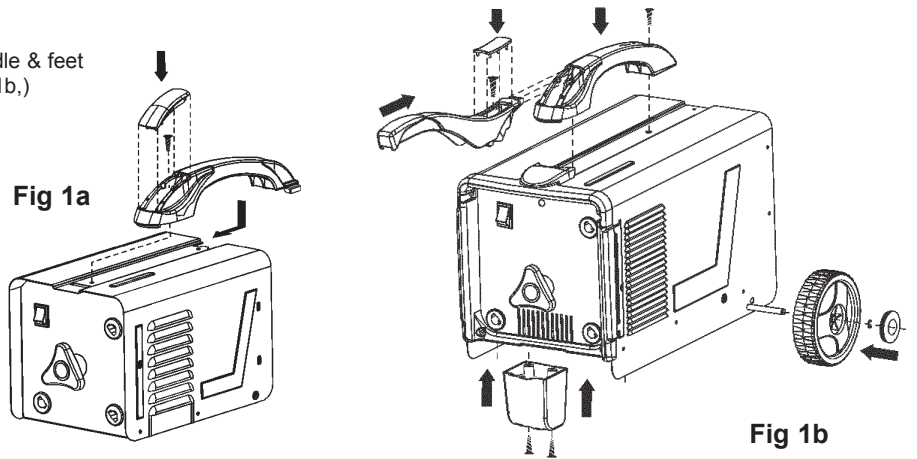

3.3. Where necessary assemble the work clamp supplied with your model to the cable associated with the work collet symbol as indicated below.

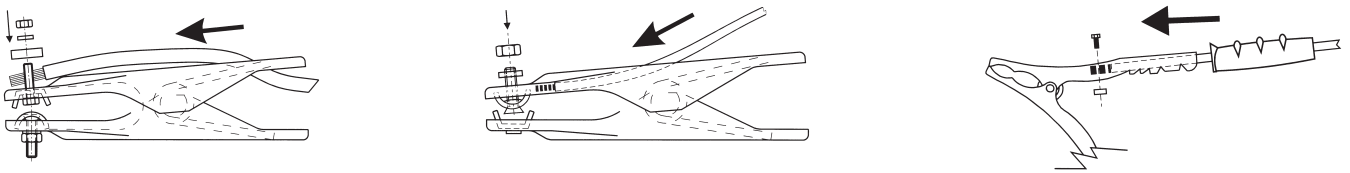

3.5. Where necessary assemble the electrode holder supplied with your model to the cable associated with the manual arc welding symbol. (see fig.3). On models with terminal style connections assemble eyelets to cables as shown in fig.3.



4. CONTROLS & SYMBOLS

The following is to assist you identify your model's control panel symbols.

<p>THERMOSTATIC PROTECTION Lights up when the machine overheats and cuts out. The machine can be used again when cooled.</p>	<p>RAIN WARNING SYMBOL <i>DO NOT</i> use the machine in the rain or snow.</p>	<p>SWITCH POSITION settings</p>	<p>ELECTRODE HOLDERS Various. The electrode holder is connected to the machine via this outlet,</p>
<p>REGULATION SCALE</p>	<p>ELECTRO-FAN Cools the machine when</p>	<p>Manual arc welder</p>	<p>Work Collet</p>
			<p>EARTH CLAMP</p>

GUIDE TO RATINGS PLATE AND SYMBOLS

(For actual ratings of your model refer to the front panel or top cover.)

FOR ANY FURTHER CLARIFICATION OF SYMBOLS REFER TO BRITISH STANDARD EN 60974-6

<p>Indicates an alternating power supply and 1 to 3 phases as required by the specification →</p>	~	U ₀ 45 ÷ 48 V		40A/19.6V - 140A/23.6V				<p>← Diameter of electrode ← Rated welding current ← Average duration of welding time in secs ← Average duration of the re-establishment time in secs. ← Effective input current (average current value considering the welding & re-establishment time.)</p>
	S	∅	1.6 mm	2.0 mm	2.5 mm	3.2 mm		
		I ₂	40 A	55 A	80 A	115 A		
		t _w	658 s	303 s	149 s	77 s		
		t _r	1142 s	597 s	751 s	823 s		
 50/60 Hz	U ₁	230 V	I ₁ max	30 A	I ₁ eff	8 A		
	Rated value of supply voltage and its current		Maximum current absorbed from the mains.					
	IP 21							
	Standard relating to moisture ingress indicating degree of protection							

5. OPERATING INSTRUCTIONS

❑ **WARNING!** If you have no welding experience, we recommend you seek supervised training from an expert source.

- 5.1. **Introduction.** Your welder features a single phase transformer with a drooping characteristic suitable for welding with an alternating current using stick electrodes with diameters from 1.5mm to the highest electrode diameter as shown on the chart below (See Fig.7).
- 5.2. **Current regulation.** The intensity of the welding current can be adjusted continuously by means of a manually operated magnetic shunt. See Fig4-2. The value of the current (I^2) may be read in amps on the graduated scale on the top or the side panel of the machine (See Fig.4-4) this corresponds to the voltage of the arc (U^2) according to the equation: $U^2 = (18+0,04I^2) V$ (EN 50060).
- 5.3. **Thermostatic Protection.** When the machine becomes overheated the built in automatic protection cuts off the supply and a yellow lamp illuminates on the front panel. See Fig.4-5. When the machine has cooled the light goes out and the supply is automatically restored. As you use larger welding rods you may experience a temporary current shut off. The larger the welding rod, the greater the current required, consequently, the hotter the machine will become and the quicker it will cut out.

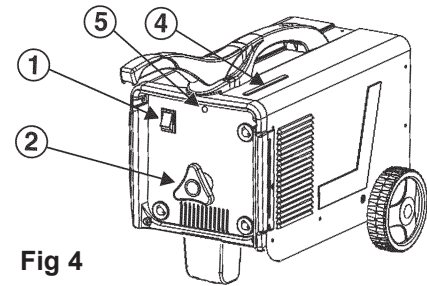

Fig 4

5.4.1 Setting up the welder.

5.4.2 Ensure the machine is turned off from the mains power supply. (See fig.4.1.)

5.4.3 Attach the earth clamp to a point on the workpiece that has been cleanly ground to provide good contact. Attach it as close as possible to the joint to be made.

5.4.4 For welders supplied with terminals the earth lead must be connected to the terminal associated with the following symbol.

5.4.1 Select the diameter of electrode to be used in relation to the type of joint to be made. Consideration should be given to the fact that higher current values should be used for flat welding, whereas for vertical or over head welding lower current values are required. Insert the electrode into the electrode holder. Ensure there is a good connection.

Ensure welding surfaces are kept clean and free from grease, or oil.

5.4.5 Establish the welding current required in relation to the diameter of electrode you are using by making reference to the table below (fig.7.)

5.4.6 Set the current required in amps using the control wheel on the front panel. See fig.4.2. The current set can be read from the graduated scale on the top or the side panel of the machine. See Fig.4.4.

5.5.1 **Commencing welding.** It is advisable to practice on scrap metal first especially where potentially difficult welds are to be undertaken.

❑ **WARNING!** Remember to wear a full face welding mask, gauntlets and protective clothing, and ensure you have read, understood and apply safety instructions. Wear goggles whilst chipping slag.

5.5.2 **DO NOT** switch on the power supply until you are fully ready to start welding.

5.5.3 Place the face mask in front of your face.

5.5.4 To strike the arc tap the electrode lightly on the workpiece as if striking a match. **DO NOT** hit the electrode on workpiece as this may damage the stick.

5.5.5 As soon as the arc is struck maintain a steady gap between the end of the electrode and the workpiece equal to the diameter of the electrode in use (See Fig 5). Try to maintain this gap continuously through out the duration of the weld. The electrode should also be held at an angle of 20° to 30° from the vertical. (See fig.6).

5.5.6 At the end of the weld bead, move the tip of the electrode backwards in order to fill the weld crater. Quickly lift the electrode from the weld pool to extinguish the arc. Refer to fig.8 for a welding fault analysis.

5.5.7 If the electrode sticks, you may be holding it too close to the workpiece. Pull sharply to the left, and then to the right to free the electrode.

5.5.8 After welding, chip off the slag with a chipping hammer. *Wear goggles.*

5.5.9 Disconnect welder from the mains power supply before resetting the electrode holder.

❑ **WARNING!** Use pliers to remove the hot consumed electrodes or to move the hot welded pieces.

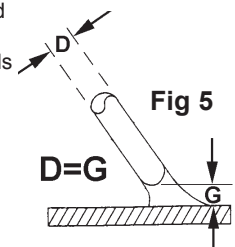

Fig 5

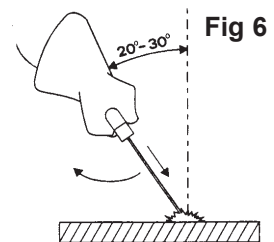

Fig 6

Electrode Diameter (mm)	Welding Current (Amp)	
	Min	Max
1.6	25	50
2.0	40	80
2.5	60	110
3.2	80	160

Fig 7

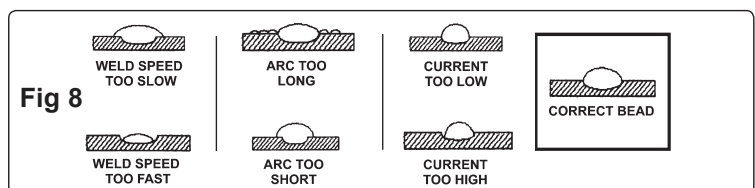

Fig 8

6. MAINTENANCE

❑ **WARNING!** Ensure the welder is disconnected from the electrical mains power supply before attempting any service or maintenance tasks outlined below.

- 6.1. Keep the welder clean and dry at all times. Use a dry cloth to clean the unit.
- 6.2. Keep all electrodes clean and ensure all cables are in good condition.
- 6.3. Inspect the welder regularly, with a frequency depending on use and the dustiness of the environment. Remove dust deposits from the transformer using a jet of dry compressed air, (Max 10bar).
- 6.4. At the same time make sure that the electrical connections are tight and check the wiring for damage to the insulation.
- 6.5. If necessary use a very thin layer of high temperature grease, to lubricate the moving parts of the regulators (threaded shaft, sliding surfaces, shunts etc.).
- 6.6. After these light maintenance operations ensure that the welder covers are replaced and that all fastening screws are fully tightened.
- 6.7. Use an authorised service agent for any other maintenance or service requirements.

❑ **WARNING!** Never perform welding operations with the covers removed.

7. TROUBLESHOOTING

- 7.1 **Machine frequently cuts out:** (A) The welder is being overworked causing the thermostatic control to activate. (B) May also be due to a sticking electrode causing the machine to cut out for up to ten minutes. Cut out will automatically reset when welder has cooled.
- 7.2 **Difficulty in striking an arc:** a). The electrode is damp. Heat it up to 60° - 70° before using.
b). Wrong type of electrode.

8. ELECTROMAGNETIC COMPATIBILITY

- 8.1 THIS EQUIPMENT IS IN CONFORMITY WITH THE EUROPEAN STANDARD ON THE ELECTROMAGNETIC COMPATIBILITY OF ARC WELDING EQUIPMENT AND SIMILAR PROCESSES (e.g. ARC AND PLASMA CUTTING)
- 8.2 **Protection against interference. (E.M.C.)** The emission limits in this standard may not, however, provide full protection against interference to radio and television reception when the equipment is used closer than 30m to the receiving antenna. In special cases, when highly susceptible apparatus is being used in close proximity, additional mitigation measures may have to be employed in order to reduce the electromagnetic emissions. At the same time there could occur some potential difficulties in having electromagnetic compatibility in a non-industrial environment (e.g. in residential areas). Therefore it is most important that the equipment is used and installed according to the following instructions.
- 8.3 **Installation and use.** The user is responsible for installing and using the equipment according to these instructions. If electromagnetic disturbances are detected, then it shall be the responsibility of the user of the equipment to resolve the situation with the technical assistance of the supplier. In some cases this remedial action may be as simple as earthing the circuit (see Note). In other cases it could involve constructing an electromagnetic screen, enclosing the welding power source and the work, complete with associated input filters. In all cases the electromagnetic disturbances shall be reduced to the point where they are no longer troublesome.
Note: The welding/cutting circuit may or may not be earthed for safety reasons. Changing the earthing arrangements should only be authorised by a person who is competent to assess whether the changes will increase the risk of injury, e.g. by allowing parallel welding/cutting circuit return paths which may damage the earth circuits of other equipment. Further guidance is given in IEC 974-13 'Arc Welding Equipment - Installation and Use.'
- 8.4 **Assessment of area.** Before installing the equipment the user shall make an assessment of potential electromechanical problems in the surrounding area. The size of the surrounding area to be considered will depend on the structure of the building and other activities that are taking place. The surrounding area may extend beyond the boundaries of the premises.
The following shall be taken into account :
a) Other supply cables, control cables, signalling and telephone cables, above, below and adjacent to the welding equipment.
b) Radio and television transmitters and receivers.
c) Computer and other control equipment.
d) Safety critical equipment, e.g. security monitoring of industrial equipment.
e) The health of people in the vicinity, e.g. persons fitted with a pacemaker or hearing aid.
f) Equipment used for calibration or measurement.
g) The immunity of other equipment in the environment. The user shall ensure that other equipment being used in the environment is compatible. This may require additional protective measures.
h) The time of day that welding and other activities are to be carried out.
- 8.5 **Mains supply.** The equipment should be connected to the mains supply according to these instructions. If interference occurs, it may be necessary to take additional precautions such as filtering of the mains supply. Consideration should also be given to shielding the supply cable of permanently installed equipment in metallic conduit or equivalent. This shielding should be connected to the power source so that good electrical contact is maintained between the conduit and the welding power source enclosure.
- 8.6 **Maintenance of the equipment.** The equipment should be routinely maintained according to these instructions. All access and service covers should be closed and properly fastened when the welding equipment is in operation. The welding equipment should not be modified in any way except for those changes and adjustments covered in these instructions. In particular, the spark gaps of any arc striking and stabilising devices should be adjusted and maintained according to the instructions.
- 8.7 **Cables.** The welding/cutting cables should be kept as short as possible and should be positioned close together, running at or close to the floor level.
- 8.8 **Equipotential bonding.** Bonding of all metallic components in the welding/cutting installation and adjacent to it should be considered. However, metallic components bonded to the workpiece will increase the risk that the operator could receive a shock by touching these metallic components and the electrode at the same time. The operator should be insulated from all such bonded metallic components.
- 8.9 **Earthing of the workpiece.** It is important that the workpiece is separately bonded to earth **in addition to** the welder/cutter return cable. Where the workpiece is not bonded to earth for electrical safety reasons or because of its size and position, e.g. ship's hull or building steelwork, a connection bonding the workpiece to earth may reduce emissions in some, but not all instances. Care should be taken to prevent the earthing of the workpiece increasing the risk of injury to others or damage to other electrical equipment. Where necessary, the connection of the workpiece to earth should be made by a direct connection to the workpiece, but in some countries where direct connection is not permitted, the bonding should be achieved by a suitable capacitance, selected according to national regulations.
- 8.10 **Screening and shielding.** Selective screening and shielding of other cables and equipment in the surrounding area may alleviate problems of interference. Screening of the entire welding/cutting installation may be considered for special applications.

NOTE: It is our policy to continually improve products and as such we reserve the right to alter data, specifications and component parts without prior notice.

IMPORTANT: No liability is accepted for incorrect use of this product.

WARRANTY: Guarantee is 12 months from purchase date, proof of which will be required for any claim.

INFORMATION: For a copy of our latest catalogue and promotions call us on 01284 757525 and leave your full name and address, including postcode.



Sole UK Distributor, Sealey Group,
Kempson Way, Suffolk Business Park,
Bury St. Edmunds, Suffolk,
IP32 7AR



01284 757500



www.sealey.co.uk



01284 703534



sales@sealey.co.uk