



INSTRUCTIONS FOR: 1.5 TON TELESCOPIC TRANSMISSION JACK

Model: 1500GTA

Thank you for purchasing a Sealey product. Manufactured to a high standard this product will, if used according to these instructions and properly maintained, give you years of trouble free performance.

⚠ IMPORTANT! ENSURE YOU READ AND UNDERSTAND THESE INSTRUCTIONS FULLY BEFORE ATTEMPTING TO USE THE JACK. NOTE THE SAFE OPERATIONAL REQUIREMENTS, DANGERS, WARNINGS & CAUTIONS. USE THE JACK CORRECTLY AND WITH CARE FOR THE PURPOSE FOR WHICH IT IS INTENDED.

⚠ WARNING! FAILURE TO APPLY THESE INSTRUCTIONS MAY CAUSE DAMAGE, SERIOUS PERSONAL OR FATAL INJURY. FAILING TO FOLLOW INSTRUCTIONS WILL ALSO INVALIDATE YOUR WARRANTY. KEEP THESE INSTRUCTIONS SAFE FOR FUTURE USE.

NOTE: The use of symbols in this document is to attract your attention to possible danger. The symbols and warnings themselves do not eliminate any danger, nor are they substitutes for proper accident prevention measures.

1. SAFETY INSTRUCTIONS

- ❑ **WARNING!** Ensure all preliminary checks are carefully carried out before use of jack. Immediately repair or replace damaged parts (use authorised service agent). Ensure use of *genuine parts only*. *Non authorised parts may be dangerous and will invalidate the warranty.*
- ❑ **WARNING!** Use jack on level and solid ground, preferably concrete. Ensure the floor over which the jack will be transported is swept clean.
- ▲ **DANGER! DO NOT use on tarmacadam, or any other soft surface as jack may sink or topple. Serious personal or fatal injury may result.**
- ▲ **DANGER! If jack tips or leans STOP WHAT YOU ARE DOING. MOVE QUICKLY TO A SAFE DISTANCE. DO NOT TRY TO HOLD OR STEADY JACK. Serious personal or fatal injury may result.**
- ✓ Use jack in an adequate working area for its function, keep area clean & tidy and free from unrelated materials. Ensure there is adequate lighting.
- ✓ Before use ensure the gearbox weight and size does not exceed the capacity of the jack.
- ✓ Ensure the vehicle is raised and stabilised at the correct height before attempting to move the jack under the vehicle.
- ✓ Keep all unauthorised persons away from the jack during lifting and lowering and when in transit.
- ✓ Maintain correct balance and footing. Ensure the floor is not slippery and wear non slip shoes.
- ✓ Remove ill fitting clothing. Remove ties, watches, rings, and other loose jewellery, and contain and/or tie back long hair.
- ❑ **WARNING!** Ensure load is placed level and centrally on jack saddle and load is fixed in place before attempting to lift, lower, or transport.
- ✓ The lowering speed will vary according to the weight of the load and the release valve setting.
- ✓ Ensure the jack saddle is fully lowered and is clean, dry, and oil free before attempting to transport the jack with or without a load.
- ✓ Fix load with support chain provided, do not substitute an inferior form of restraint for the support chain.
- ✓ Diligence is required in ensuring that you continually monitor the operation until completed.
- ✓ Should jack omit any abnormal sounds during use STOP immediately and contact your local service agent.
- ❑ **WARNING!** DO NOT operate jack if any parts are damaged or missing .
- x DO NOT exceed the rated capacity of the jack.
- x DO NOT allow untrained persons to operate the jack.
- x DO NOT place any part of your body within or under the jack during use.
- x DO NOT raise or lower vehicle lifting platform whilst the transmission jack is being used.
- x DO NOT transport the jack, with or without a load, with the saddle in the raised position.
- x DO NOT get jack wet or use in damp or wet locations or areas where there is condensation.
- x DO NOT operate jack when you are tired, under the influence of alcohol, drugs or intoxicating medication.
- x DO NOT lift or support vehicles with jack and do not use jack as a load sustaining device.
- x DO NOT use jack for any purpose other than removal, transportation, installation of transmissions.
- x DO NOT use jack without support chain or substitute an inferior form of restraint for the chain.
- x DO NOT make any modifications to the jack, and DO NOT adjust or tamper with safety valve.
- x DO NOT remove any labels from the jack. If labels are damaged or unclear replace them.
- ✓ Use a qualified person to lubricate and maintain the jack. DO NOT use brake fluid to top up hydraulic unit. Use Sealey hydraulic oil only.
- ✓ Before storing in safe area, ensure all parts are clean, free of grease and oil (especially saddle). Lower saddle to the lowest position.

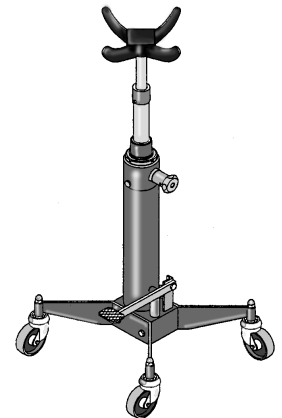

2. SPECIFICATIONS

Rated capacity	1500kg
Ram extensions	2
Minimum saddle base height	900mm
Maximum saddle base height	1910mm
Base size	.910

3. ASSEMBLY

Unpack the product and check contents. Should there be any damaged or missing parts contact your supplier immediately.

- 3.1. Assemble wheels as in figure 1.
- 3.2. Screw legs to the base of the stand and check that the stand is at a right angle to an horizontal plan, then tighten the leg screws.
- 3.3. Place the saddle on the end of the central stand.
- 3.4. Remove the transportation oil plug and replace with the operating plug (identified by a hole in the plug head fig 2).

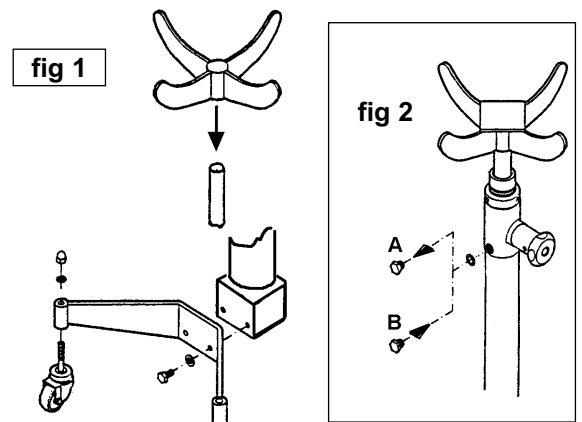

4. PRE-USE CHECK LIST

IMPORTANT

IMPORTANT: Before *EACH* use, check jack is in sound working order, use following list to form a habitual pre-check procedure. Check items are not: *damaged, broken, cracked, bent, malfunctioning, distorted, worn, loose, damage to welds, leaking, dirty, noisy or missing.*

- | | | |
|---------------------------------------|----------------------------|------------------------------|
| 1. . . .Saddle base | 5. . . .All nuts and bolts | 8. . . .Foot pumps |
| 2. . . .Piston rod | 6. . . .All seals | 9. . . .Swivel caster wheels |
| 3. . . .Cylinder/Hydraulic unit | 7. . . .Jack main frame | 10. . .Transport handle |
| 4. . . .Stopper rings and cotter pins | | |

- WARNING! DO NOT use jack if any suspect part is found, or if believed to have been subjected to abnormal load or shock. Immediately remove from service and contact your authorised service agent.**

4.2. IMPORTANT: BEFORE THE FIRST USE OF JACK PURGE AIR FROM THE HYDRAULIC CIRCUIT.

Before using the jack for the first time, purge the hydraulic circuit in order to eliminate any air, that may have accumulated in the system during transit, as follows:

1. Open the release valve by turning knob anti-clockwise.
2. Pump the jack handle up and down 15 to 20 times.
3. Turn the release valve clockwise to close the valve.

5. OPERATING INSTRUCTIONS

- WARNING! Before use ensure you have read, understood and apply Section 1 safety instructions.**
- WARNING! Ensure you prepare vehicle correctly before attempting to use the Transmission Jack.**

5.1. POSITIONING JACK BENEATH LOAD.

Before use ensure the transmission weight and size does not exceed the capacity of the jack.

- 5.1.1. Ensure the vehicle from which the gearbox is to be removed is correctly positioned, raised and locked on appropriate lift system.
- 5.1.2. Ensure there are no other persons around or under the vehicle.
- 5.1.3. Ensure saddle is in lowest position and use handle to transport and centrally position jack beneath vehicle transmission.
- 5.1.4. Pump the jack foot peddle and the saddle will rise (fig 3).
- 5.1.5. When saddle is just beneath the transmission re-adjust alignment if necessary to centralise the saddle.

5.2. LOWERING THE LOAD.

- WARNING! Ensure the load is central and stable on the jack saddle and load is fixed in place before attempting to lift, lower, or transport. SLOWLY** turn the release valve knob anti-clockwise (fig 4) to **GENTLY** lower saddle to the lowest minimum height before attempting to transport the load.
- * **IMPORTANT:** Speed of lowering is controlled by release valve. The quicker the valve knob is turned the more rapid the jack's descent. Ensure the jack's descent is slow and controlled to avoid the risk of sudden dropping which would be very dangerous.

5.3. TRANSPORTING THE LOAD.

- WARNING! Ensure you have read, understood and apply Section 1 safety instructions.**
- 5.3.1. Ensure the jack saddle is fully lowered and load is fixed in place before attempting to lift, lower, or transport.

- 5.3.2. Transport the load over level and solid ground, preferably concrete, and ensure the floor is swept clean beforehand.
 - 5.3.3. Be diligent in continually monitoring the load in transit. Keep all other persons at a safe distance.
- ▲ **DANGER! DO NOT use on tarmacadam, or any soft surface as jack may sink or topple. Serious personal or fatal injury may result.**
- ▲ **DANGER! If jack tips or leans STOP WHAT YOU ARE DOING. MOVE QUICKLY TO A SAFE DISTANCE. DO NOT TRY TO HOLD OR STEADY JACK. Serious personal or fatal injury may result.**

Note this jack may be used with appropriate adaptors in order to handle such components as rear axle units and transfer cases that are within the weight limitations of the jack.

5.4. RE-INSTALLING A GEARBOX.

To transport, reposition beneath a vehicle, and raise a load up, reverse the procedures outlined above.

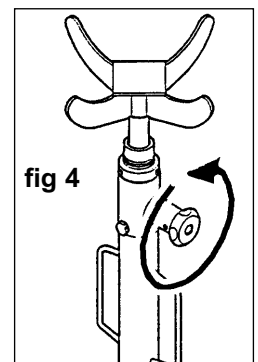
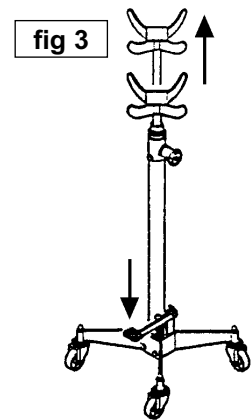

6. MAINTENANCE

IMPORTANT: Only fully qualified personnel should attempt maintenance or repair.

- 6.1. When the jack is not in use, the saddle must be in the lowest position to minimise ram and piston corrosion.
- 6.2. Keep the jack clean and wipe off any oil or grease. Lubricate all moving parts with acid free oil.
- 6.3. The oil cylinder is a sealed unit and must not be accessed. For service contact your authorised dealer.
- ☐ **WARNING! Only a good quality Jack oil, such as SEALEY HYDRAULIC JACK OIL must be used, DO NOT use brake fluid.**
- 6.4. Before each use, follow the pre-check list to ensure components are not damaged, broken, cracked, bent, malfunctioning, distorted, worn, loose, any visible damage to welds, leaking, dirty, noisy or missing (see Section 4). If any suspect item is found remove jack from service and take necessary action to remedy the problem.
DO NOT use the jack if believed to have been subjected to abnormal load or shock. Inspect and take appropriate action.
- 6.5. Periodically check the pump piston and piston rod for signs of corrosion. Clean exposed areas with a clean oiled cloth.

IMPORTANT: NO RESPONSIBILITY IS ACCEPTED FOR INCORRECT USE OF THE MACHINE.

Hydraulic products are only repaired by local service agents. We have service/repair agents in all parts of the UK. **DO NOT RETURN JACKS TO US.** Please telephone 01284 757500 to obtain address and phone number of your local agent. If Jack is under guarantee please contact your dealer.

De-commissioning the jack: Should the jack become completely unserviceable and require disposal, draw off the oil into an approved container and dispose of the jack and the oil according to local regulations.

7. TROUBLESHOOTING

IMPORTANT! Although the following may identify a problem, in most cases the problem must be resolved by your authorised service agent.

PROBLEM	CAUSE	SOLUTION
Jack will not lift	No hydraulic oil, or defective suction valve or delivery valve Release valve is open	Contact authorised service agent. Close release valve.
Jack will only lift halfway	Hydraulic oil low, or excess of hydraulic oil	Contact authorised service agent.
Raised load will not hold	Defective valves, or defective piston packing	Contact authorised service agent.
Poor lifting	Defective plunger packing	Contact authorised service agent.

Declaration of Conformity We, the sole importer into the UK, declare that the product listed below is in conformity with the following EEC standards and directives.

1.5 Ton Telescopic Vehicle Transmission Jack
Model 1500GTA
98/37/EC Machinery Directive
(S.I. 1992/3073)
93/68/EEC CE Marking Directive



The construction file for this product is held by the Manufacturer and may be inspected on request by contacting Jack Sealey Ltd.

Signed by Mark Sweetman

1st March 2000

For Jack Sealey Ltd., Sole importer into the UK of Sealey Quality Machines

NOTE: It is our policy to continually improve products and as such we reserve the right to alter data, specifications and component parts without prior notice.

IMPORTANT: No liability is accepted for incorrect use of this equipment

WARRANTY: Guarantee is 12 months from purchase date, proof of which will be required for any claim.

INFORMATION: For a copy of our latest catalogue and promotions call us on 01284 757525 and leave your full name and address, including postcode.



Sole UK Distributor
Sealey Group,
Bury St. Edmunds, Suffolk.



01284 757500



01284 703534

E-mail: sales@sealey.co.uk