



INSTRUCTIONS FOR 2 TONNE LOW ENTRY TROLLEY JACK MODEL NO: 1020LE

Thank you for purchasing a Sealey product. Manufactured to a high standard, this product will, if used according to these instructions, and properly maintained, give you years of trouble free performance.

IMPORTANT: PLEASE READ THESE INSTRUCTIONS CAREFULLY. NOTE THE SAFE OPERATIONAL REQUIREMENTS, WARNINGS & CAUTIONS. USE THE PRODUCT CORRECTLY AND WITH CARE FOR THE PURPOSE FOR WHICH IT IS INTENDED. FAILURE TO DO SO MAY CAUSE DAMAGE AND/OR PERSONAL INJURY AND WILL INVALIDATE THE WARRANTY. KEEP THESE INSTRUCTIONS SAFE FOR FUTURE USE.



Refer to
instructions



Wear safety
footwear

1. SAFETY

- ✓ Ensure the jack is in sound condition and good working order. Take action for immediate repair or replacement of damaged parts. Use genuine parts only. The use of unapproved parts may be dangerous and will invalidate the warranty.
- ✓ Locate the jack in a suitable, well lit working area.
- ✓ Keep working area clean and tidy and free from unrelated materials.
- ✓ Use jack on level and solid ground, preferably concrete. Avoid tarmac as jack may sink in.
- ✓ Place wedges under wheels of vehicle (but ensure wheels of jack can freely move).
- ✓ Ensure the vehicle handbrake is engaged, engine is switched off and transmission is in gear (or "PARK" if automatic).
- ✓ Ensure minimum distance of 0.5m between vehicle and static objects such as doors, walls, etc., to allow for vehicle tilting.
- ✓ Ensure there are no passengers in the vehicle.
- ✓ Ensure all non-essential persons keep a safe distance whilst the jack is in use.
- ✓ Only place jack under those lifting points recommended by vehicle manufacturer (see vehicle hand book).
- ✓ Check the lifting point is stable and centred on the jack saddle.
- ✓ Ensure the jack wheels are free to move and that there are no obstructions.
- ✓ When lifting a load at the jack's maximum rating (2tonne) or close to it, it is recommended that the effort of raising the load be reduced by the use of assistance during this operation.
- ▲ **DANGER:** Use the jack for lifting only, **NOT** for supporting the lifted load.
- ✓ Use suitable capacity axle stands under the vehicle before proceeding with any task.
- ✓ Ensure there are no persons or obstructions beneath the vehicle before lowering.
- ✓ Use a qualified person to maintain or repair the jack hydraulic system.
- * **DO NOT** operate the jack if damaged.
- * **DO NOT** allow untrained persons to operate the jack.
- * **DO NOT** exceed the rated capacity of the jack.
- * **DO NOT** allow the vehicle to move while supported by the jack, or use the jack to move the vehicle.
- * **DO NOT** jack vehicle if there is a risk of spillage of fuel, battery acid, or other dangerous substances.
- * **DO NOT** work under the vehicle until axle stands have been correctly positioned.
- * **DO NOT** use the jack for purposes other than those for which it is intended.
- * **DO NOT** top up hydraulic system with brake fluid. Use hydraulic jack oil only.
- * **DO NOT** adjust the safety overload valve.
- ✓ When not in use store jack, fully lowered, in a safe, dry, childproof area.

2. INTRODUCTION

Heavy-duty chassis with strengthening flanges along the top edge for extra torsional rigidity under load. Profiled lifting arm allows low clearance height of just 86mm making this unit suitable for sports and custom cars. Fitted with heavy-duty one-piece hydraulic unit with pump-through action preventing handle locking at maximum ram extension. White saddle aids positioning under vehicle and safety valve prevents overloading.

3. SPECIFICATION

Model No.....	1020LE
Capacity.....	2tonne
Min. Saddle.....	86mm
Max. Saddle height.....	380mm
Chassis Height.....	154mm
Length.....	415mm
Weight.....	12.6kg

4. OPERATION

4.1. Before first use.

- 4.1.1. Before using jack, purge hydraulic unit in order to eliminate any air in the system. Place handle onto the release valve nut as shown in fig.2 and open the valve by turning the handle anti-clockwise, place the handle back into the jacking socket and pump for 30 to 40 seconds. See fig.1. When complete, close the release valve by turning the valve nut clockwise. Place a few drops of hydraulic jack oil onto the pump piston and pump the handle several times to distribute the oil. Thoroughly lubricate all moving parts.

4.2. General jacking.

- WARNING!** Before lifting ensure Section 1 safety instructions are read and understood.

- 4.2.1. Prepare the vehicle as mentioned in the safety instructions ensuring the ground on which the jack is to stand is level and solid (not tarmacadam).

- 4.2.2. Position the jack saddle under the vehicle manufacturer's recommended lifting point.

4.3. Jacking the vehicle.

- 4.3.1. Close the release valve using the handle as shown in fig.2. Place the handle into the handle socket and commence pumping handle up and down using maximum strokes until vehicle.

- 4.3.2. Should the jack become overloaded, a safety excess pressure valve will open, and stop the vehicle from lifting.

- WARNING!** The jack is a lifting device only and must not be used to support the load. Use correctly rated axle stands to support the load.

- 4.3.3. When lifting a load at the jack's maximum rating (2tonne) or close to it, it is recommended that the effort of raising the load be reduced by the use of assistance during the operation.

4.4. Lowering the vehicle

- WARNING!** Ensure there are no persons or obstacles beneath the vehicle, or in the path of its descent.

- 4.4.1. If using axle stands, raise the jack high enough for the stands to be easily removed. Then place the handle onto the release valve nut and turn anti-clockwise, very slowly, to open the valve.

- 4.4.2. The lowering speed is controlled by the amount you turn the handle. Lower carefully, avoid any sudden changes in descent rate which would shock load the hydraulic system.

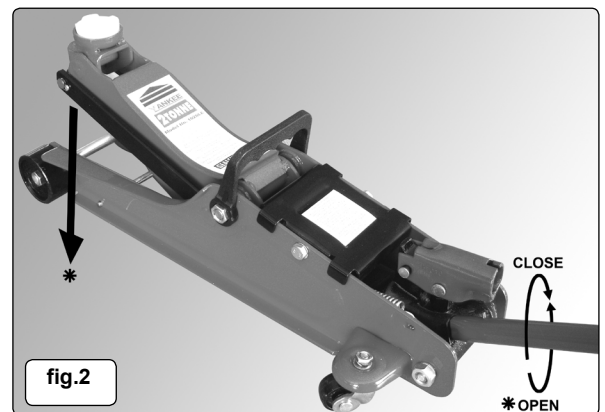
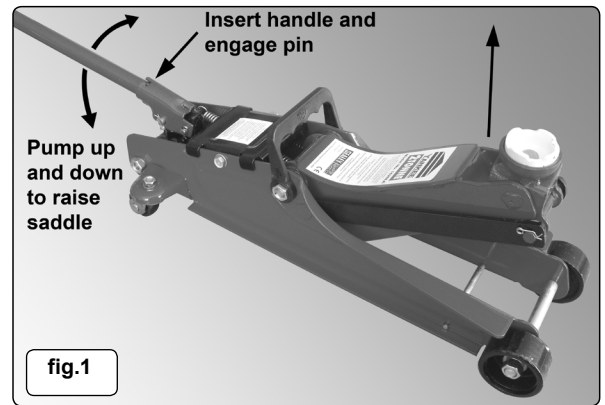

5. MAINTENANCE

- 5.1. When the jack is not in use, the ram should be in its lowest position to minimise corrosion. Remove the handle to inactivate jack.
- 5.2. Keep the jack clean and lubricate all moving parts on a regular basis.
- 5.3. Before each use check for broken, cracked, bent, or loose parts, or any visible damage to ram, pump, saddle, lifting arm, frame and all parts including nuts, bolts, pins and other fasteners. If any suspect item is found remove jack from service and take necessary action to remedy the problem.
- * **DO NOT** use the jack if believed to have been subjected to abnormal load or shock load.
- 5.4. Periodically check the pump piston and the ram for signs of corrosion. Clean exposed areas with a clean oiled cloth.
- 5.5. After one year the oil should be replaced in order to extend the life of the jack. Use hydraulic jack oil only.
- ✓ **IMPORTANT:** Only fully qualified personnel should attempt hydraulic maintenance or repair.
- 5.6. To check the oil level, fully lower the jack. Remove the two bolts that hold the black cover in place and prise out the cover from between the side walls of the jack. Remove oil filler plug (fig.3). The correct level is just below the bottom of the plug. If oil level is low, fill as required. Replace cover. **NOTE:** Use a good quality jack oil, such as **SEALEY HYDRAULIC JACK OIL**.
- WARNING! DO NOT** use brake fluid, or any fluid other than hydraulic jack oil as this may cause serious damage to the jack and will invalidate the warranty.
- 5.7. When draining the oil make sure that no dirt is allowed to enter the hydraulic system.
- ✓ **IMPORTANT: NO RESPONSIBILITY IS ACCEPTED FOR INCORRECT USE OF THIS PRODUCT.**
- Hydraulic products are only repaired by local service agents. We have service/repair agents in all parts of the UK. **DO NOT** return jacks to us. Please telephone us on 01284 757500 to obtain the address and phone number of your local agent. If jack is under guarantee contact your local Sealey dealer.
- De-commissioning the Jack. Should the jack become completely unserviceable and require disposal, draw off the oil into an approved container and dispose of the jack and the oil according to local regulations.

6. TROUBLE SHOOTING

6.1. If jack will not lift load.

- 6.1.1. Oil level may be low. Check oil level as described in section 5.6. and top up if necessary.
- 6.1.2. To ensure complete distribution of the oil go through the following procedure. Close the release valve and manually pull the lifting arm up to its full height. Open the release valve and, by stepping on the saddle, force the arm to lower as rapidly as possible. Repeat this operation three or four times. This procedure also thoroughly flushes the valves and in most cases will restore the jack to full working order. The jack may have air trapped in the system. To eliminate trapped air open the release valve and pump the handle through its full stroke six times. Close release valve.
- 6.1.3. After several months of service the pump 'O' ring seal may become worn. If this is suspected take the jack to an approved agent for servicing.
- 6.1.4. The release valve may be held open by dirt on the valve seat. Flush by pulling the lifting arm up and down several times manually while the release valve is open.
- 6.1.5. The load is heavier than 2 tonnes and the overload valve has operated. The overload valve is factory set and should not be altered.

6.2. If jack will not hold the load.

- 6.2.1. The discharge valve may be held open by dirt on the seat. Perform the procedure described in section 6.1.2. If this does not solve the problem take the jack to an approved agent for servicing.
- 6.2.2. Where a jack has received heavy service the ram cup seal may become worn. If this is suspected take the jack to an approved agent for servicing.
- 6.2.3. Release valve partially open. Fully close release valve.

6.3. If jack will not lower completely.

- 6.3.1. The lifting arm return spring may be broken or unhooked. Replace return spring.
- 6.3.2. Jack requires lubrication. Clean and oil all moving parts in the lifting arm mechanism.
- 6.3.3. Hydraulic unit is overfilled with oil. Drain off excess oil.

6.4. Jack will not lift full 2 tonne load.

- 6.4.1. Piston 'O' ring seal may have become worn. If this is suspected take the jack to an approved agent for servicing.
- 6.4.2. The jack may have air trapped in the system. See section 6.1.2.
- 6.4.3. The load is heavier than 2 tonnes and the overload valve has operated. The overload valve is factory set and should not be altered.
- 6.4.4. Jack frame/link system distorted due to overloading or poor positioning. Return to an approved service agent for replacement of damaged parts.

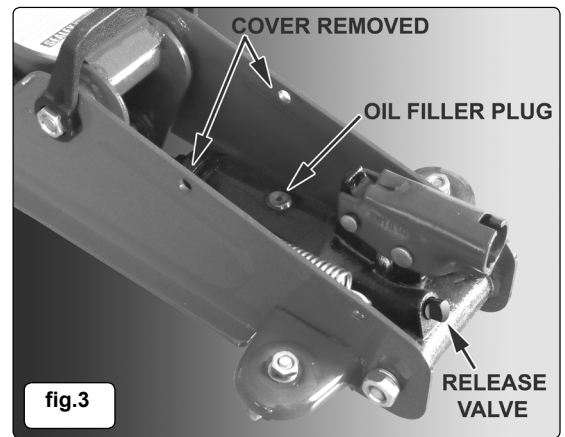

Parts support is available for this product. To obtain a parts listing and/or diagram, please log on to www.sealey.co.uk, email sales@sealey.co.uk or telephone 01284 757500.



Environmental Protection

Recycle unwanted materials instead of disposing of them as waste. All tools, accessories and packaging should be sorted, taken to a recycling centre and disposed of in a manner which is compatible with the environment. When the product becomes completely unserviceable and requires disposal, drain off any fluids (if applicable) into approved containers and dispose of the product and the fluids according to local regulations.

NOTE: It is our policy to continually improve products and as such we reserve the right to alter data, specifications and component parts without prior notice.

IMPORTANT: No liability is accepted for incorrect use of this product.

WARRANTY: Guarantee is 12 months from purchase date, proof of which will be required for any claim.



Sole UK Distributor, Sealey Group.
Kempson Way, Suffolk Business Park,
Bury St. Edmunds, Suffolk.
IP32 7AR



01284 757500



01284 703534



www.sealey.co.uk



sales@sealey.co.uk