

NEW

Multi Profile Cutter Blocks 60/80 x 5.5mm

- Hard wearing steel body complete with two tool steel rebate knives and limiter plates.
- Suitable for jointing, rebating and profiling with 5.5mm thick knives and limitors in un-bonded softwood and hardwood boards on a spindle moulder.
- Cutter block will take both 60mm and 80mm knives and limitors.
- Recommended RPM (n): 4,000 – 5,800.
- Suitable for Hand Feeding (MAN).

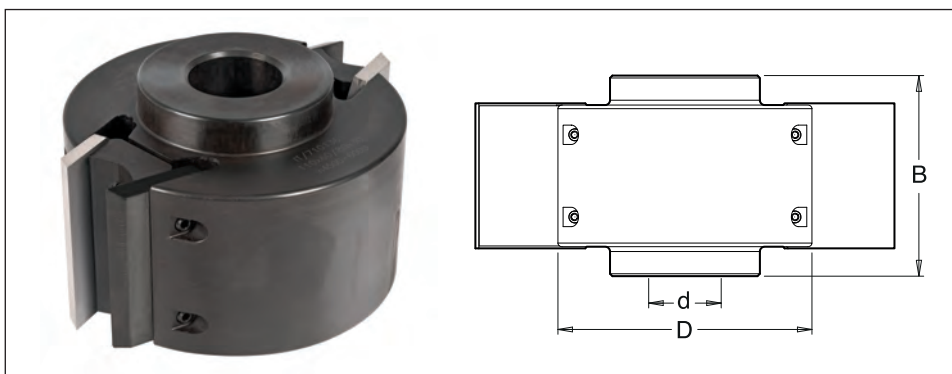
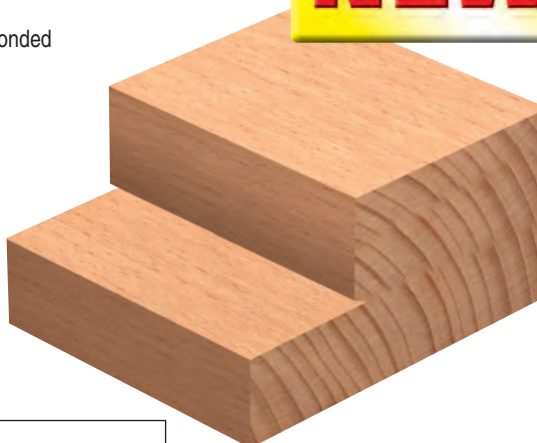

D	B	z	30mm Bore d	1 1/4" Bore d	Stock	Price
110	60/80	2	IT/710 136 1	IT/710 136 7	Y	£150.00

Key
Stock - Y means normally kept in stock for next day delivery.
 N means not normally held in stock, delivery in a short time.

Please note:
 Multi-profile block 128mm dia x 1-1/4" bore for 60mm knives only is still available while stocks last.
 Ref. IT/776 030 7 - £132.30

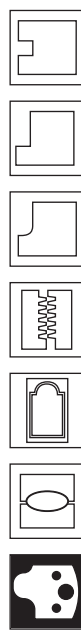

Tool Steel Multi Profile Cutters - 60x5.5mm

All drawings are actual size
 Profile drawing shows back of knife

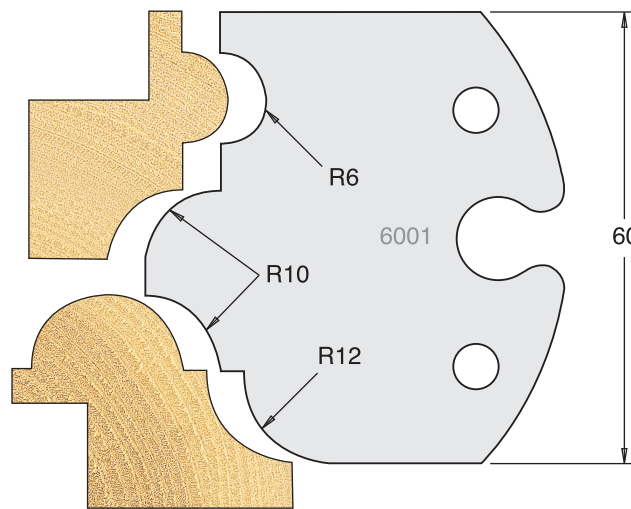
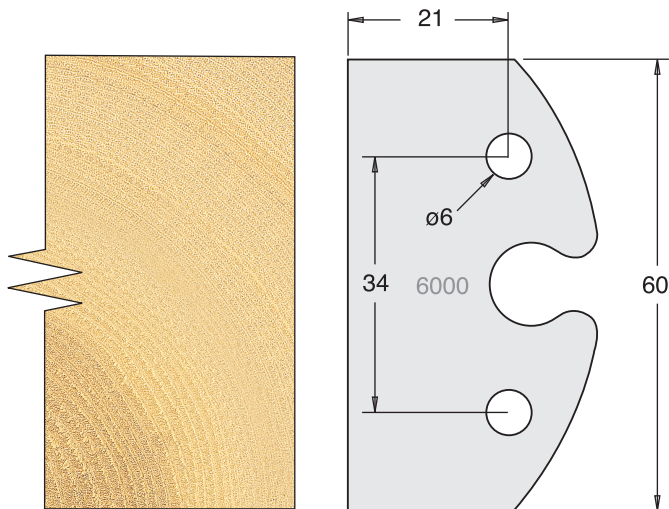

Knives	IT/33 000 60	£21.74
Limitors	IT/34 000 60	£23.10

Knives	IT/33 001 60	£28.35
Limitors	IT/34 001 60	£23.10

All blades sold as a pair
 All prices are exclusive of VAT