

Lamello® Disposable Insert Biscuit Joint Cutter

- Hard wearing steel body complete with disposable Tungsten Carbide knives (z) and scribes (v).
- Suitable for producing biscuit joint slots in softwood, hardwood and man-made boards with a biscuit jointing machine.
- Constant diameter and groove width through disposable tips. More cost effective than standard tipped cutter.
- Fits all standard biscuit jointers.
- Recommended RPM (n): 7,700 – 15,000.
- Suitable for Hand Feeding (MAN).

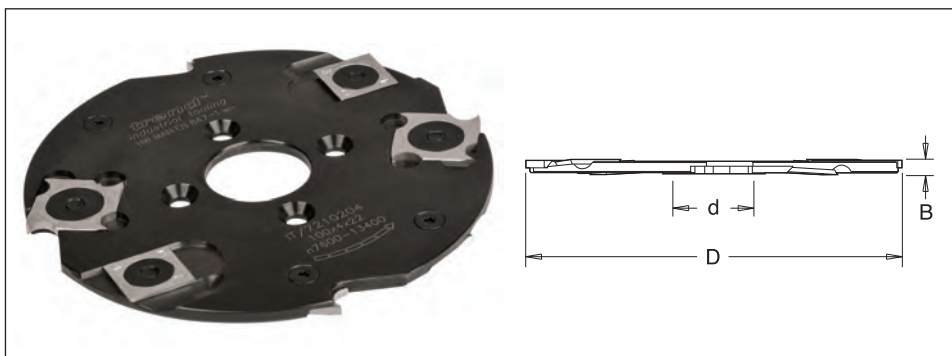

Hand Feed

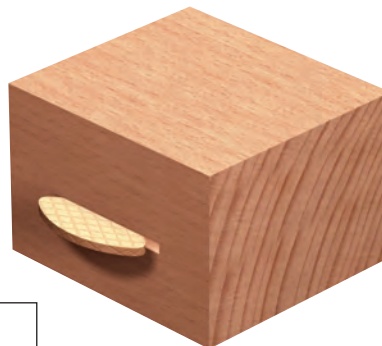

EN847-1/2

D	z	v	B	22mm Bore d	Stock	Price
100	4	4	4	IT/721 020 4	Y	£103.53

Spare Knives and Scorers

Description	T.C. Blade	
Product Ref.	IT/300 850 1/10	IT/300 850 2/10
Size	18x18x2	14x14x1.2
Price	£55.00	£25.52



CE

For details of the T20K Biscuit Jointer please see the latest Trend Routing & Woodworking Catalogue.



Edge Joints



Mitre Joints



Bevel Joints

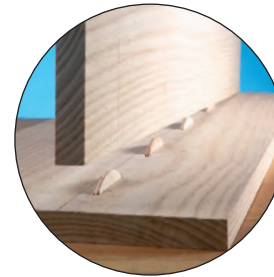

T-joints

Key

Spare Knives and Scorers - Product Reference ending in /10 are sold in packs of ten

Stock - Y means normally kept in stock for next day delivery.

N means not normally held in stock, delivery in a short time.