

Disposable Insert Panel Raising Cutter Block

- Hard wearing alloy body complete with disposable Tungsten Carbide knives (z).
- Suitable for producing raised panel profiles in softwood, hardwood and man-made boards on a spindle moulder.
- The cutter block works over the top of the timber.
- Recommended RPM (n): 3,800 – 6,500.
- Suitable for Hand Feeding (MAN).

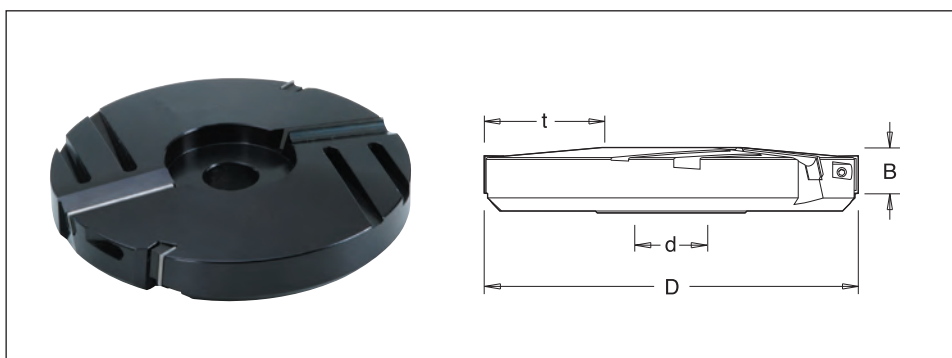

Hand Feed

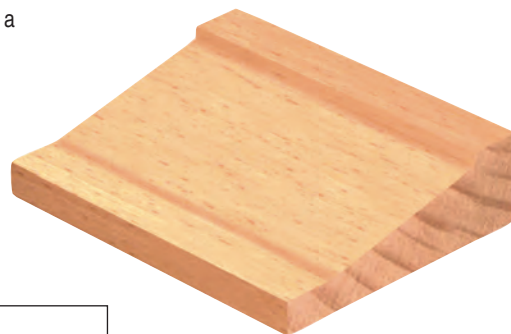

EN847-1/2

D	B	z	max. t	30mm Bore d	1 1/4" Bore d	Stock	Price
200	35	2+2	58	IT/751 010 1	IT/751 010 7	Y	£206.01

Spare Knives

Description	T.C. Blade	
Product Ref.	IT/310 722 0/10	IT/300 053 1/10
Size	20x12x1.5	60x12x1.5
Price	£49.00	£51.03

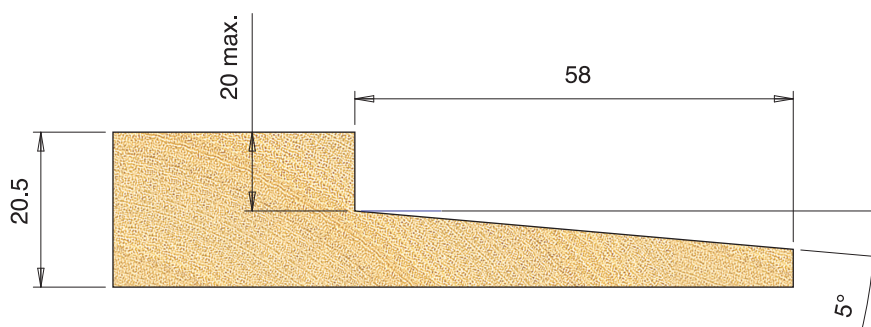

Key

Spare Knives and Scorers - Product Reference ending in /10 are sold in packs of ten

Stock - Y means normally kept in stock for next day delivery.

N means not normally held in stock, delivery in a short time.