

Multi Profile Panel Raising Cutter Block

NEW

- Hard wearing alloy body only. Knives and limitors are purchased separately.
- Suitable for producing various raised panel profiles in softwood and hardwood boards on a spindle moulder.
- The cutter block works over the top of the timber for panel raising.
- Each knife will also produce a 45° chamfer with the timber running over the top of the knife.
- All of the tool steel knives and corresponding limitor plates (1 – 7) can be used in the same block.
- Recommended RPM (n): 4,500 – 7,000.
- Suitable for Hand Feeding (MAN).

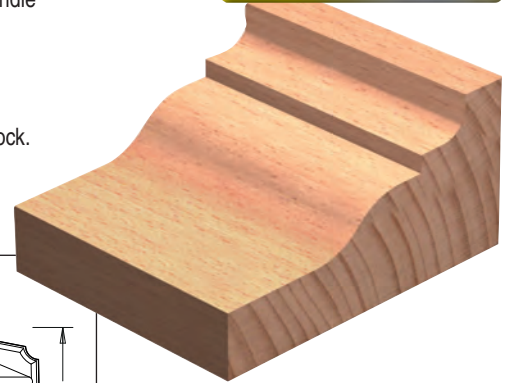

Please note: Cutter block is supplied without knives and limitors, and works over the top of the panel.

D	B	z	30mm Bore d	1 1/4" Bore d	Stock	Price
160	48	2	IT/778 101 1	IT/778 101 7	Y	£139.00

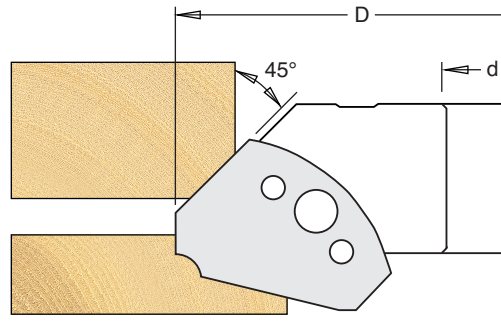
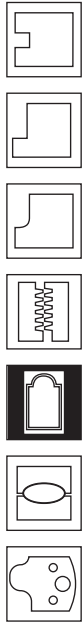

Panel Raising Tool Steel Knives

■ Panel raising tool steel knives and corresponding limitor plates (700 - 701) to suit cutter block IT/778 101 1 and IT/778 101 7.

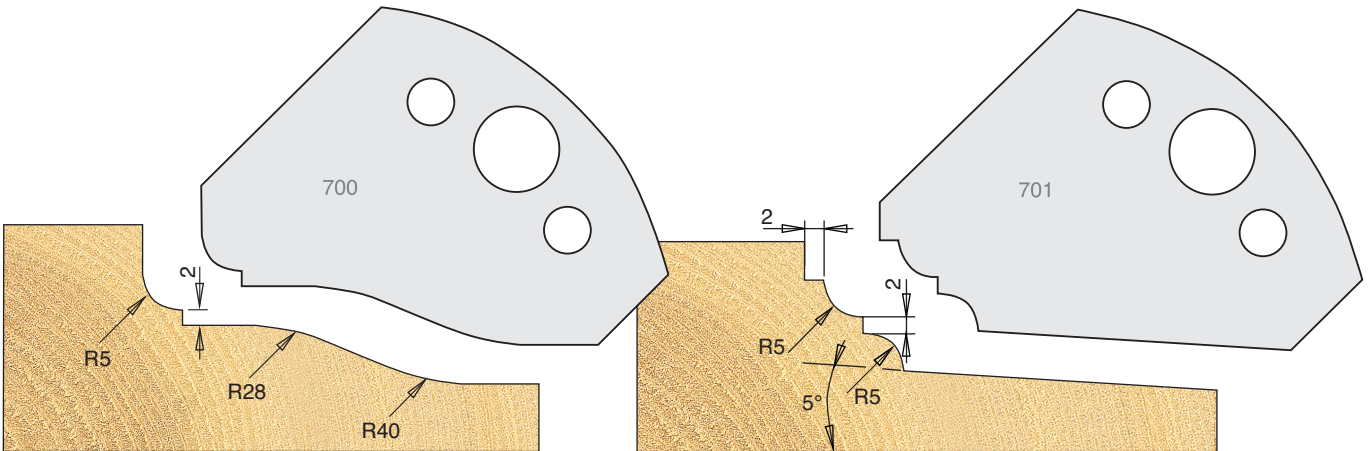

Tool Steel Knives	IT/33 700 40	£24.00
HSS Knives	IT/33 700 43	£55.00
Limitors	IT/34 700 40	£19.00

NEW

Tool Steel Knives	IT/33 701 40	£24.00
HSS Knives	IT/33 701 43	£55.00
Limitors	IT/34 701 40	£19.00

NEW

Key

Stock - Y means normally kept in stock for next day delivery.
N means not normally held in stock, delivery in a short time.

All knives and limitor plates sold as a pair
All prices are exclusive of VAT