

Disposable Insert Profile/Counter Profile Cutter Blocks

- Hard wearing alloy body complete with disposable Tungsten Carbide knives (z).
- Suitable for producing various profile/counter profile joints in softwood and hardwood on a spindle moulder.
- Raising or lowering the cutter block on the spindle moulder produces both parts of the joint.
- All of the Tungsten Carbide inserts (profile A – D) can be used in the same block.
- Recommended RPM (n): 5,000 – 8,400.
- Suitable for Hand Feeding (MAN).

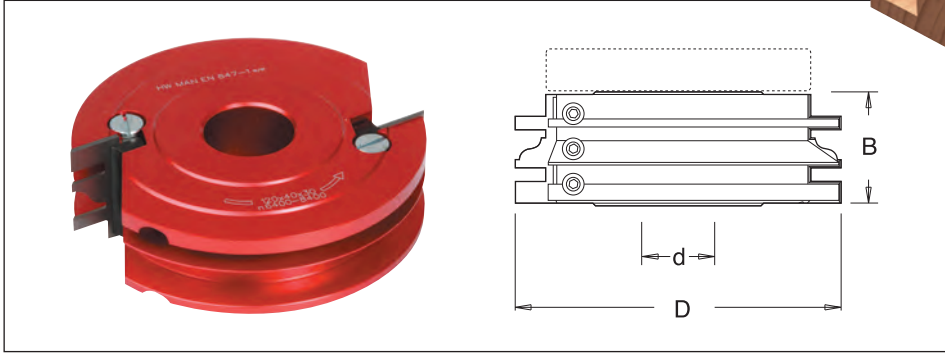

Hand Feed

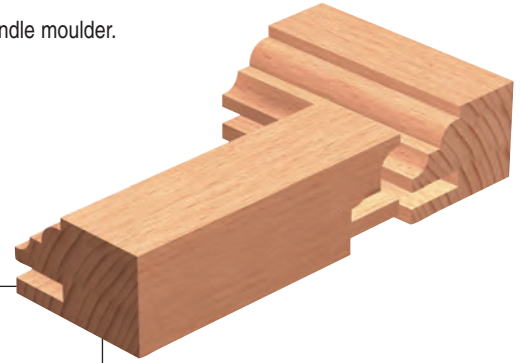

EN847-1/2

D	Profile	z	B	30mm Bore d	1 1/4" Bore d	Stock	Price
120	A	2	40	IT/742 031 1	IT/742 031 7	Y	£140.81
120	B	2	40	IT/742 032 1	IT/742 032 7	Y	£140.81
120	C	2	40	IT/742 033 1	IT/742 033 7	Y	£140.81
120	D	2	40	IT/742 034 1	IT/742 034 7	Y	£140.81

Spare Knives

Description	T.C. Blade			
Product Ref.	IT/310 865 6	IT/310 866 6	IT/310 867 6	IT/310 868 6
Size	40x26x2 Profile A	40x26x2 Profile B	40x26x2 Profile C	40x26x2 Profile D
Price	£33.00	£33.00	£33.00	£33.00

Ball Bearing Guide

Description	Ball Bearing	
Product Ref.	IT/191 520 1	IT/191 520 7
Size	98x15x30	98x15x1 1/4"
Price	£31.71	£31.71

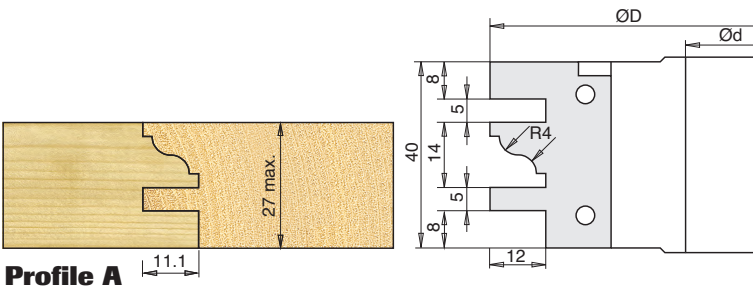
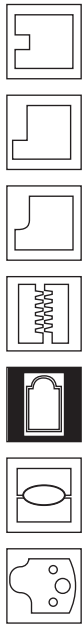

Profile A

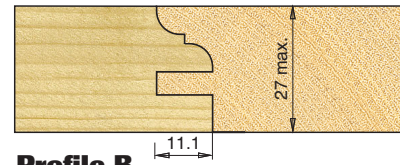

Profile B

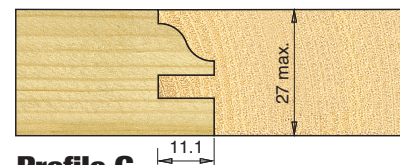

Profile C

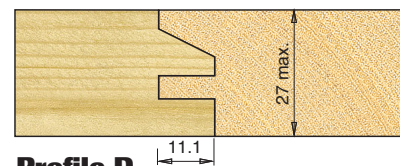

Profile D

Key

Spare Knives and Scorers - Product Reference ending in /10 are sold in packs of ten
Stock - Y means normally kept in stock for next day delivery.
 N means not normally held in stock, delivery in a short time.