

## Disposable Insert 45° Mitre Lock Cutters

- Hard wearing alloy body complete with disposable Tungsten Carbide knives (z).
- Suitable for producing 45° mitre lock joints in softwood, hardwood and man-made boards on a spindle moulder.
- A 45° joint is produced by machining one piece with the inside face on the table of the spindle moulder. The matching corner inside face is machined upright against the fence.
- Recommended RPM (n): 5,500 – 10,000.
- Suitable for Hand Feeding (MAN).

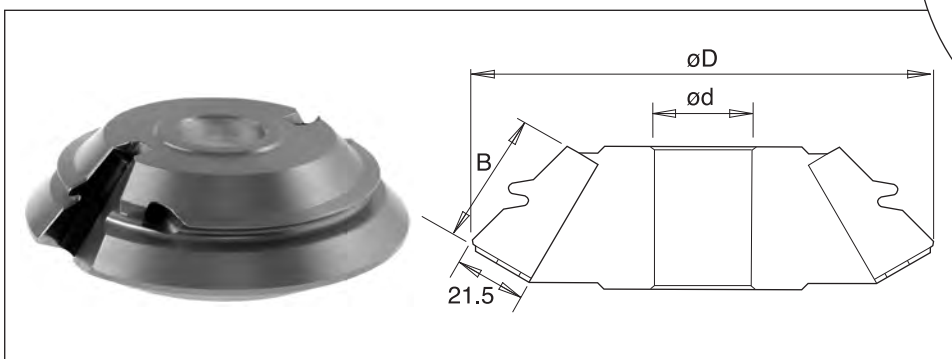
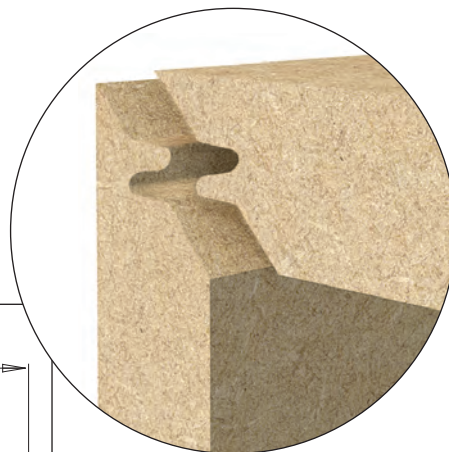

Hand Feed

EN847-1/2

D	B	z	30mm Bore d	1 1/4" Bore d	Stock	Price
140	40	2	IT/ST/ML 001	IT/ST/ML 007	Y	£242.45

### Spare Knife

Description	T.C. Blade
Product Ref.	IT/ST/IB01
Size	40x12x1.5
Price	£40.95

### Spare Part

Description	Spare Top Screw
Product Ref.	IT/SS/01
Size	M4x6
Price	£1.68

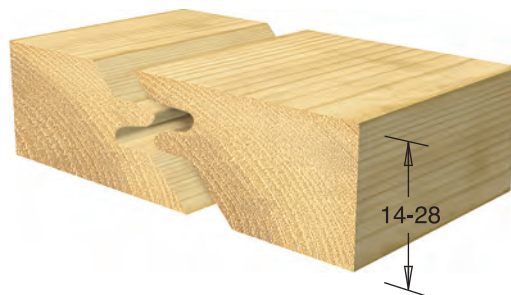
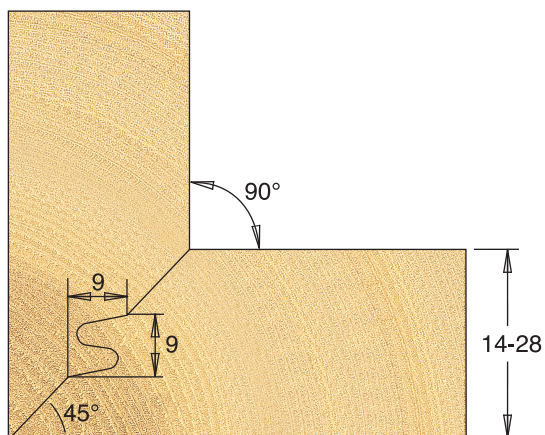

### Key

**Spare Knives and Scorers** - Product Reference ending in /10 are sold in packs of ten  
**Stock** - Y means normally kept in stock for next day delivery.  
 N means not normally held in stock, delivery in a short time.