

Disposable Insert Glue Joint Cutter Blocks

- Hard wearing steel and alloy body complete with disposable Tungsten Carbide knives (z).
- Suitable for producing "finger style" reversible glue joints in softwood and hardwood on a spindle moulder.
- Recommended RPM (n): 120mm diameter 6,500 – 9,500. 140mm diameter 5,400 – 8,800.
- Suitable for Hand Feeding (MAN).

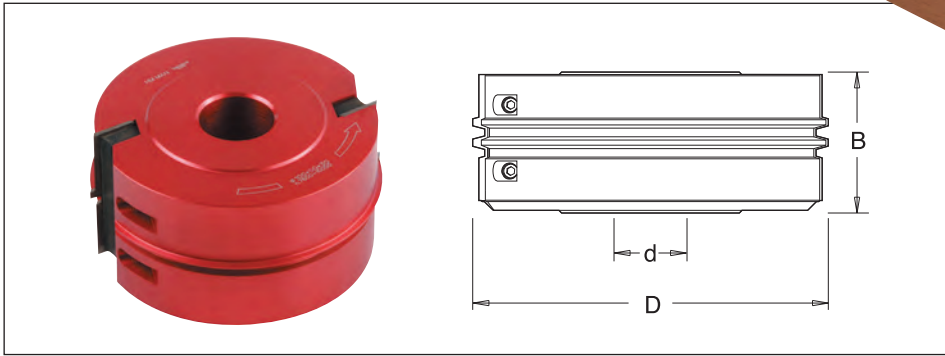
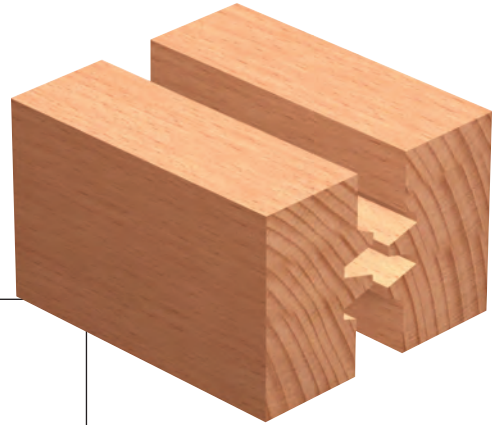

| D | Profile | z | B | 30mm Bore d | 1 1/4" Bore d | Stock | Price |
|-----|---------|---|----|---------------|---------------|-------|---------|
| 120 | A | 2 | 60 | IT/741 004 1* | IT/741 004 7* | N | £211.26 |
| 140 | B | 2 | 50 | IT/741 006 1 | IT/741 006 7 | Y | £228.27 |
| 140 | C | 2 | 60 | IT/741 005 1 | IT/741 005 7 | Y | £251.90 |

* Hard wearing alloy body

Spare Knives

| Description | T.C. Blade | | |
|--------------|--------------------|--------------------|--------------------|
| Product Ref. | IT/310 855 1 | IT/310 855 2 | IT/310 850 1 |
| Size | 60x24x2 1 tooth | 50x24x2 2 teeth | 60x24x2 3 teeth |
| Price | £42.00 | £44.00 | £49.00 |

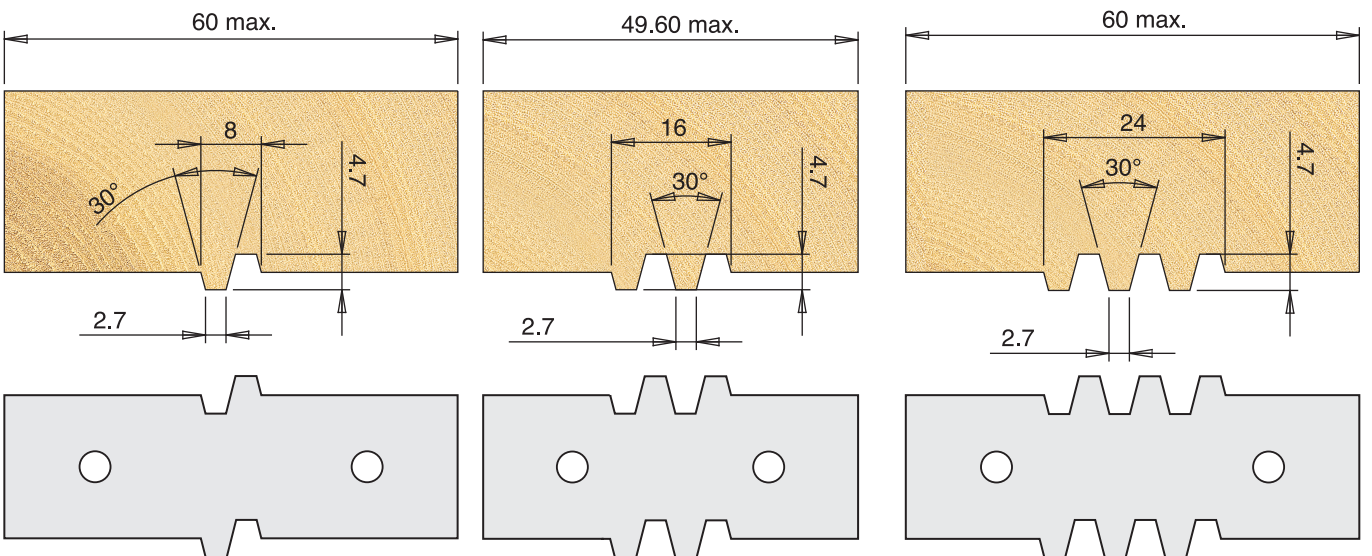

Profile A

Scale 1:1

Profile B

Profile C

Key

Spare Knives and Scorers - Product Reference ending in /10 are sold in packs of ten

Stock - Y means normally kept in stock for next day delivery.

N means not normally held in stock, delivery in a short time.