

Disposable Insert Rounding Over Cutter Blocks

- Hard wearing alloy body complete with disposable Tungsten Carbide knives (z).
- Suitable for rounding over one side of softwood, hardwood and man-made boards on a spindle moulder.
- Cutter block supplied as standard with R8 knives, same body will accept R3 - R10 knives. R15 - R30 require separate blocks.
- Can be used with a 100mm diameter ball bearing guide ring.
- Recommended RPM (n) 120mm diameter 6,400 – 10,000. 130mm – 160mm diameter 5,400 – 9,000.
- Suitable for Hand Feeding (MAN).

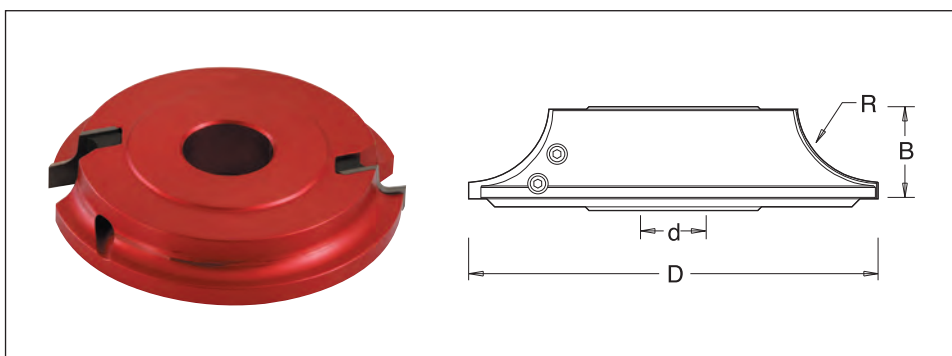
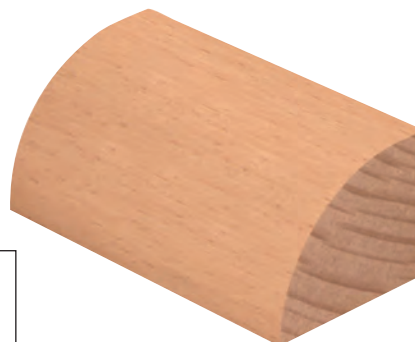

Hand Feed

EN847-1/2

D	R	z	B	30mm Bore d	1 1/4" Bore d	Stock	Price
120	8	2	20	IT/752 428 1	IT/752 428 7	Y	£166.85
120	3 - 10	2	20	IT/752 410 1*	IT/752 410 7*	Y	£319.41
130	15	2	20	IT/752 435 1	IT/752 435 7	Y	£188.58
140	20	2	25	IT/752 440 1	IT/752 440 7	Y	£188.58
150	25	2	30	IT/752 445 1	IT/752 445 7	Y	£188.58
160	30	2	35	IT/752 450 1	IT/752 450 7	Y	£188.58

* Complete Set of Cutter Block and Knives, R3-R10, supplied in a wooden box.

Spare Knives

Description	T.C. Blade									
	R=3	R=4	R=5	R=6	R=8	R=10	R=15	R=20	R=25	R=30
Product Ref.	IT/310 890 3	IT/310 890 4	IT/310 890 5	IT/310 890 6	IT/310 890 8	IT/310 891 0	IT/310 891 5	IT/310 892 0	IT/310 892 5	IT/310 893 0
Price	£17.54	£17.54	£17.54	£17.54	£17.54	£20.37	£24.00	£30.00	£34.50	£39.00

Ball Bearing Guide to suit R3 - R10 Cutter Blocks

Description	Ball Bearing	
Product Ref.	IT/191 540 1	IT/191 540 7
Size	100x15x30	100x15x1 1/4"
Price	£31.71	£31.71

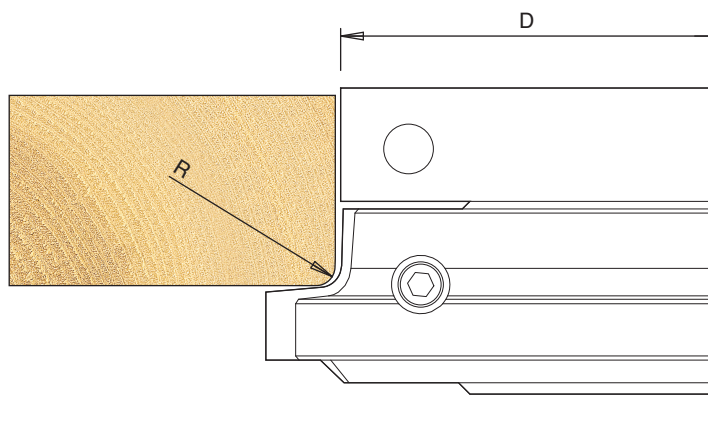

Key

Spare Knives and Scorers - Product Reference ending in /10 are sold in packs of ten

Stock - Y means normally kept in stock for next day delivery.

N means not normally held in stock, delivery in a short time.