

## Dial Adjustable Disposable Insert Grooving Cutters with Scorers 4-24mm

- Hard wearing steel body complete with disposable Tungsten Carbide knives (z) and scorers (v).
- Suitable for producing various width grooves and slots in softwood, hardwood and man-made boards on a spindle moulder.
- Cutting width can be adjusted by 0.1mm using adjustable dial gauge without removing tool from machine.
- Recommended RPM (n) 160mm diameter 4,800 – 8,300. 180mm diameter 4,300 – 7,500.
- Suitable for Hand Feeding (MAN).

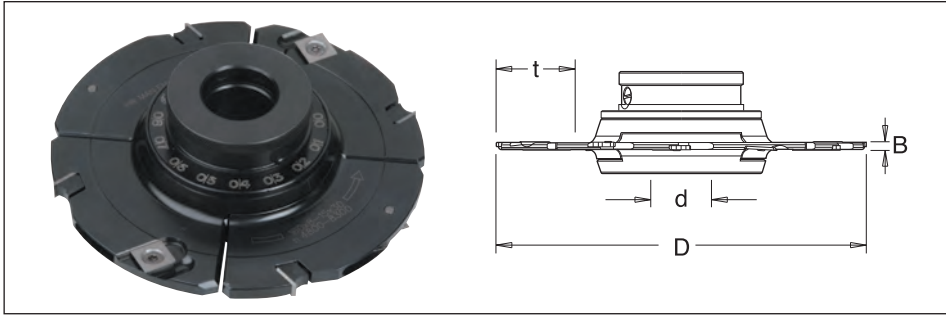
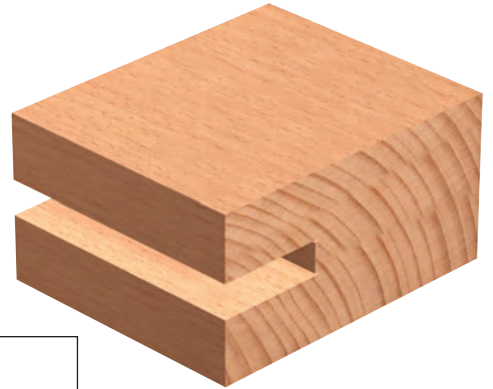

D	B	z	v	max. t	30mm Bore d	1 1/4" Bore d	Stock	Price
160	4.0 - 7.5	8	4	30	IT/722 016 1	IT/722 016 7	Y	£379.89
160	8.0 - 15.0	4	4	30	IT/722 008 1	IT/722 008 7	Y	£330.75
160	12.5 - 24.0	4	4	30	IT/722 009 1	IT/722 009 7	Y	£348.29
180	4.0 - 7.5	8	4	40	IT/722 017 1	IT/722 017 7	Y	£407.30
180	8.0 - 15.0	4	4	40	IT/722 011 1	IT/722 011 7	Y	£356.27
180	12.5 - 24.0	4	4	40	IT/722 012 1	IT/722 012 7	Y	£376.64

### Spare Knives

Description	T.C. Blade			
	Product Ref.	IT/310 850 1/10	IT/310 751 2/10	IT/300 750 9/10
Size	18x18x2 B=4-7.5mm	7.5x12x1.5 B=8-15mm	11.6x12x1.5 B=12.5-24mm	
Price	£55.00	£30.77	£35.00	

### Spare Scorers

Description	T.C. Blade		
	Product Ref.	IT/300 850 2/10	IT/300 850 3/10
Size	14x14x1.2 B=4-7.5mm	14x14x2 B=8-24mm	
Price	£25.52	£20.37	

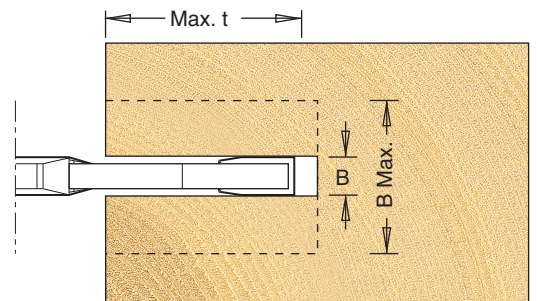
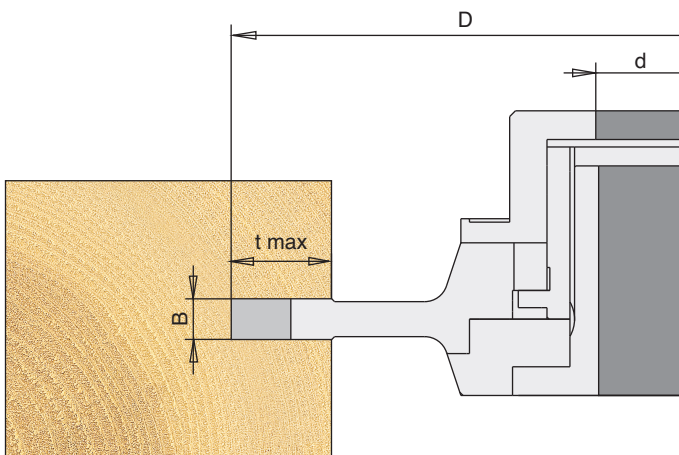

### Key

**Spare Knives and Scorers** - Product Reference ending in /10 are sold in packs of ten

**Stock** - Y means normally kept in stock for next day delivery.

N means not normally held in stock, delivery in a short time.