

### 3 Part Disposable Insert Adjustable Grooving Cutters with Scorers 4-30mm

- Hard wearing steel body complete with disposable Tungsten Carbide knives (z) and scorers (v).
- Suitable for producing various width grooves and slots in softwood, hardwood and man-made boards on a spindle moulder.
- Cutting width can be adjusted by 0.1mm by using supplied spacer rings.
- Recommended RPM (n) 5,500 – 8,000.
- Suitable for Hand Feeding (MAN).

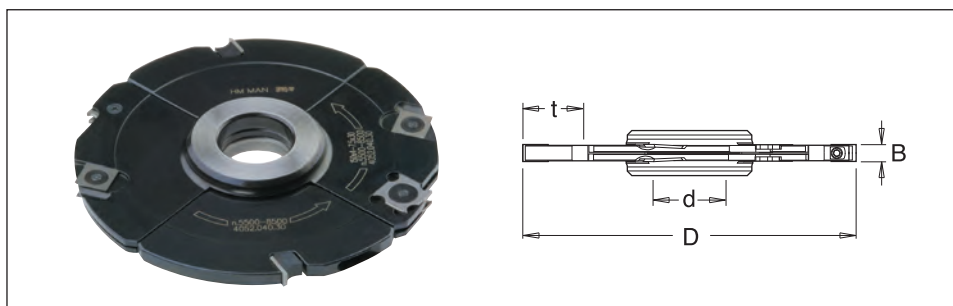
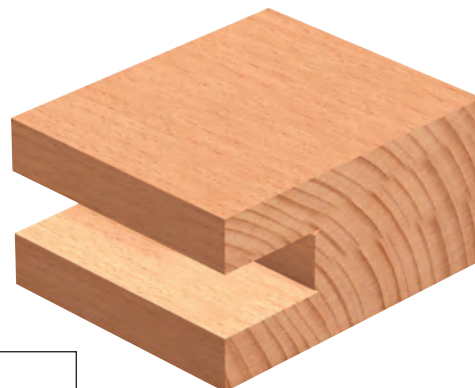

D	B	z	v	max. t	30mm Bore d	1 1/4" Bore d	Stock	Price
150	4.0 - 15.5	4+2	4	45	IT/722 030 1	IT/722 030 7	Y	£386.09
N 150	8.0 - 30.0	4+2	4	45	IT/ST/AG001	IT/ST/AG007	Y	£459.00

#### Spare Knives

Description	T.C. Blade			
	Product Ref.	IT/300 850 1/10	IT/ST/TCI01	IT/310 751 2/10
Size	18x18x2 B=4-15.5mm	15x12x1.5 B=8-30mm	7.5x12x1.5 B=4-30mm	
Price	£55.00	£4.50	£30.77	

#### Spare Scorers

Description	T.C. Blade		
	Product Ref.	IT/300 850 2/10	IT/300 850 3/10
Size	14x14x1.2 B=4-15.5mm	14x14x2 B=8-30mm	
Price	£25.52	£20.37	

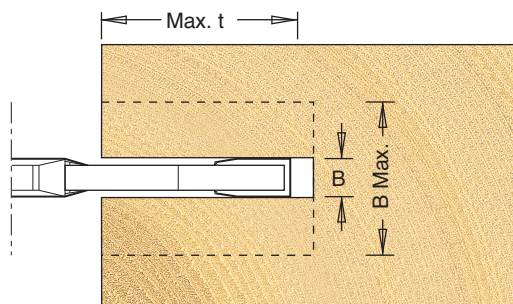
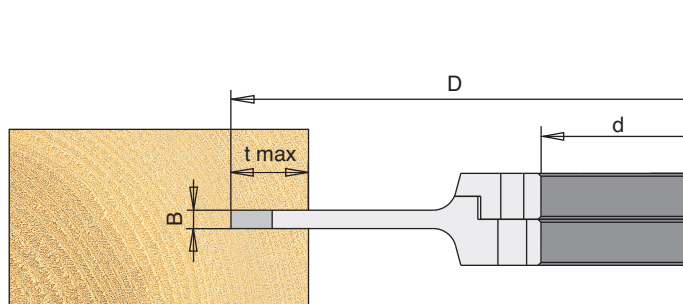

#### Key

**Spare Knives and Scorers** - Product Reference ending in /10 are sold in packs of ten  
**Stock** - Y means normally kept in stock for next day delivery.  
 N means not normally held in stock, delivery in a short time.