

Non-Ferrous Sawblades

- Suitable for trimming with a medium/fine finish on solid aluminium bars.
- Triple chip tooth.
- Material must be firmly clamped on both sides of cut and sawblade should be lubricated during use.
- For use on mitre, double cross-cutting and sizing machines.
- Other bore sizes available, see page 17.

NEW

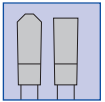

Aluminium

**Triple Chip Teeth
Medium/Fine Finish**

TCT

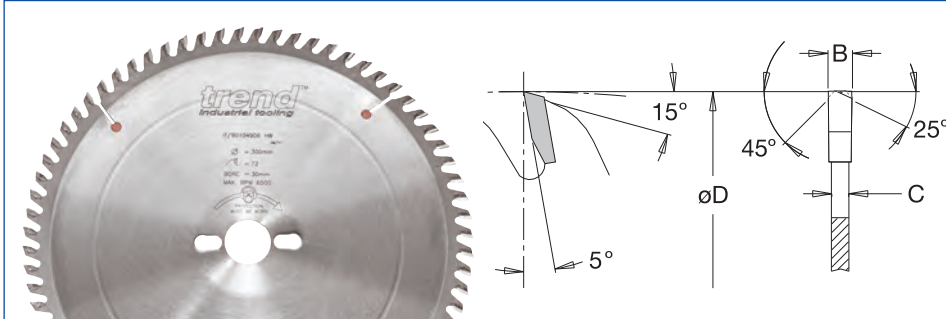

	øD	Teeth	Product Ref.	B	C	ø bore	Stock	Price
N	300	60	IT/902 50 10 6	3.4	2.8	30	Y	£113.40
N	300	80	IT/902 54 00 6	3.4	2.8	30	Y	£133.35
N	350	80	IT/902 50 20 6	3.6	3.0	30	Y	£144.90
N	350	100	IT/902 54 30 6	3.6	3.0	30	Y	£165.90
N	400	80	IT/902 50 30 6	3.8	3.2	30	Y	£160.95
N	400	120	IT/902 54 50 6	3.8	3.2	30	Y	£178.50
N	450	80	IT/902 56 00 6	4.0	3.4	30	Y	£191.10
N	450	100	IT/902 50 40 6	4.0	3.4	30	Y	£199.50
N	500	80	IT/902 56 03 6	4.2	3.5	30	Y	£211.05
N	500	100	IT/902 50 50 6	4.2	3.5	30	Y	£235.20
N	550	100	IT/902 56 06 6	4.4	3.8	30	Y	£288.75
N	550	120	IT/902 50 60 6	4.4	3.8	30	Y	£297.15

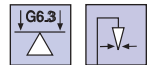

Stock Y normally kept in stock for next day delivery N not normally held in stock, delivery in a short time