

Rip Sawblades

- Suitable for rip cutting with a coarse finish on solid soft and hard woods.
- Flat tooth with large gullet for fast chip removal.
- For use on a bench, table or rip saw.
- Other bore sizes available, see page 17.

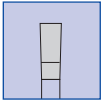

Solid Wood
Flat Teeth
Coarse Finish

TCT

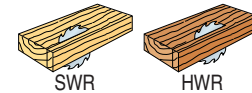
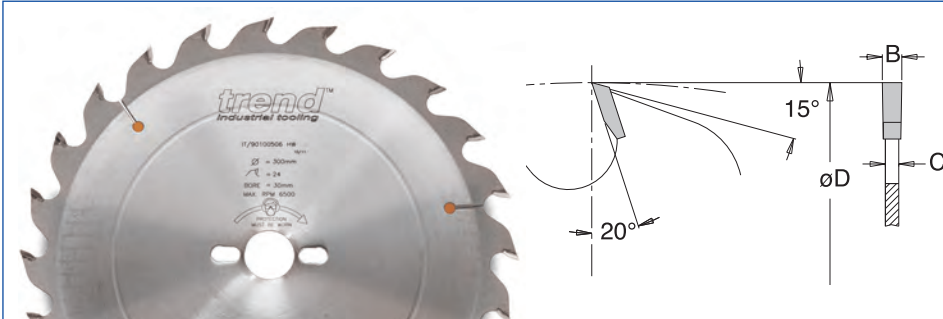

øD	Teeth	Product Ref.	B	C	ø bore	Stock	Price
250	20	IT/901 00 30 6	3.2	2.2	30	Y	£40.85
250	24	IT/901 00 40 6	3.2	2.2	30	Y	£42.53
300	24	IT/901 00 50 6	3.2	2.2	30	Y	£50.72
300	30	IT/901 00 60 6	3.2	2.2	30	Y	£56.28
350	28	IT/901 00 70 6	3.5	2.5	30	Y	£63.42
400	32	IT/901 00 80 6	3.5	2.5	30	Y	£71.19
450	32	IT/901 00 84 6	4.0	2.8	30	Y	£80.01
500	36	IT/901 00 85 6	4.4	3.0	30	Y	£97.65

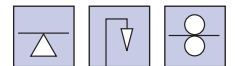

Rip Sawblades - Thicker Tip and Plate

- Suitable for rip cutting with a coarse finish on solid soft and hard woods.
- Thicker Tungsten Carbide Tip and saw body for heavy duty applications.
- For use on a bench, table or rip saw.
- Other bore sizes available, see page 17.

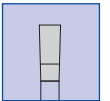

Solid Wood
Flat Teeth
Coarse Finish

TCT

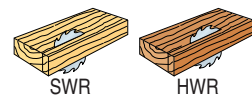
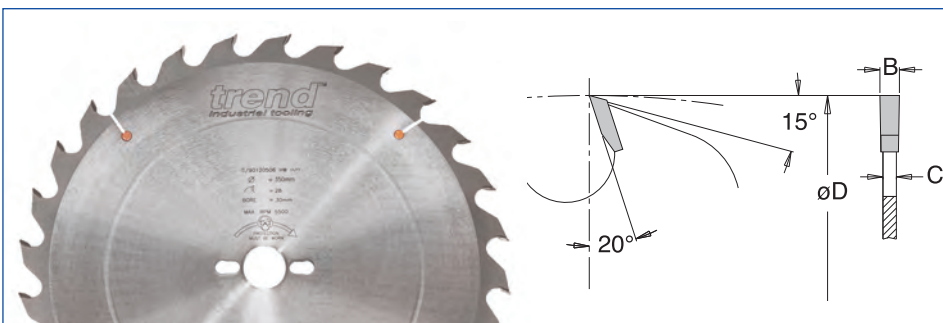

øD	Teeth	Product Ref.	B	C	ø bore	Stock	Price
300	24	IT/901 20 20 6	4.0	2.8	30	N	£66.15
300	24	IT/901 20 30 6	4.4	2.8	30	N	£66.15
350	28	IT/901 20 60 6	4.0	2.8	30	N	£80.54
350	28	IT/901 20 50 6	4.4	2.8	30	Y	£80.54
400	32	IT/901 21 10 6	4.0	3.0	30	N	£92.09
400	32	IT/901 20 90 6	4.4	3.0	30	N	£92.09

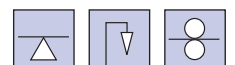

Stock Y normally kept in stock for next day delivery N not normally held in stock, delivery in a short time