

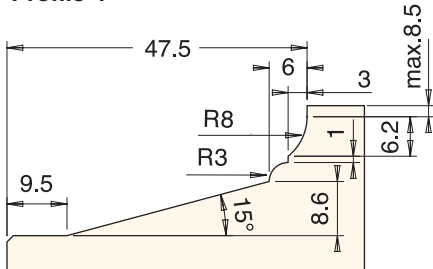

CNC MACHINING

Disposable Insert Multi Profile Raised Panel Router Cutters

Profile 4



Profile 5

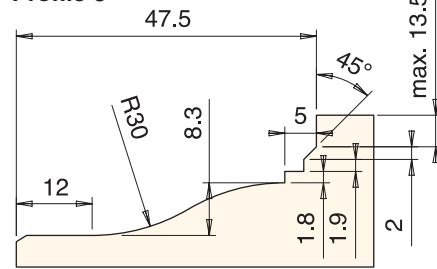

Profile 6

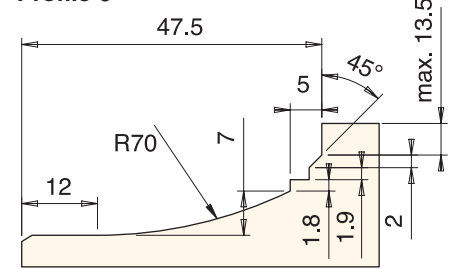

Profile 7

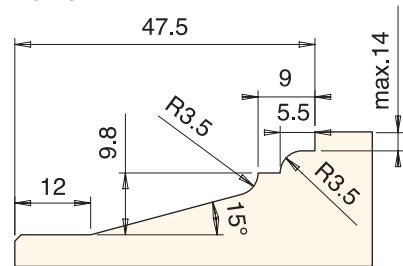

Profile 8

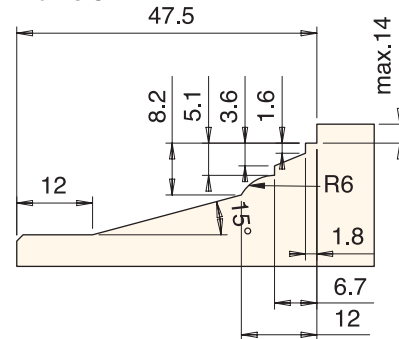

Disposable Insert Straight Rebating Cutters with Scorers Z2/V2

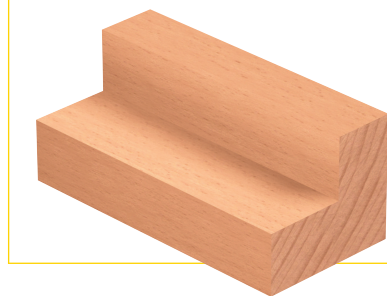

Disposable insert rebating router cutter complete with two cutting flutes and scorers. Suitable for trimming and rebating in softwoods, hardwoods and man made boards. Scorers will give an improved finish at the bottom of the cut. For use on routers and machining centres with CNC control.

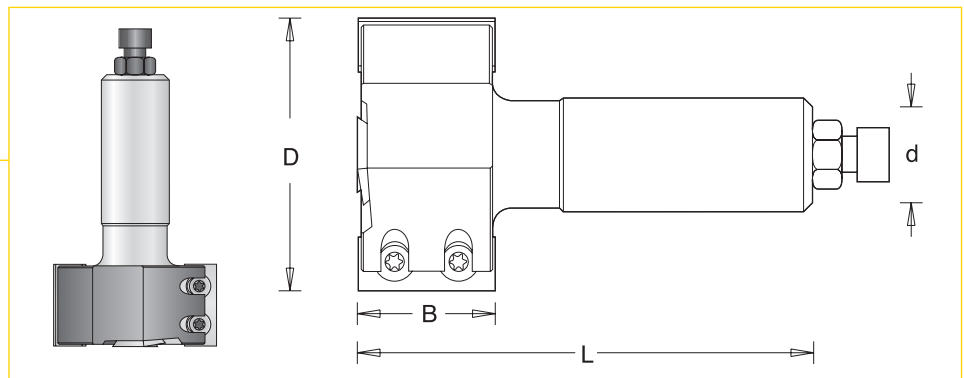

øD	Product Ref.	B	L	ød	n
40	IT/807 330 0	30	100	20x55	18,000
40	IT/807 332 0	50	120	20x55	18,000
60	IT/807 335 0	30	100	20x55	18,000
60	IT/807 337 0	50	120	20x55	18,000

⚠ Also available with 25mm diameter shank, replace the last digit with an 'H'.

Spare Parts

Description	T.C. Blade		Torx® Screw	Torx® Key
Product Ref.	IT/310 123 0/10	IT/310 125 0/10	IT/193 148 1	IT/194 101 5
Size	30x12x1.5	50x12x1.5	M4x5.6	T15
			M5x6.3	T20

Blades sold in packs of ten.