

CNC MACHINING

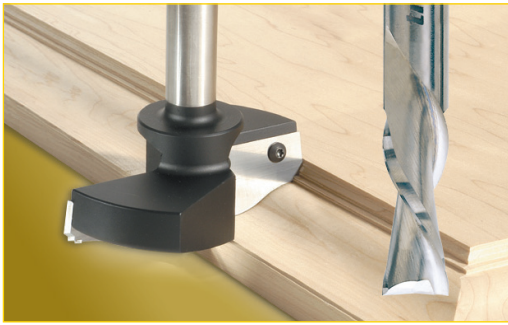

Disposable Insert Straight Router Cutters

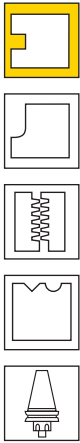

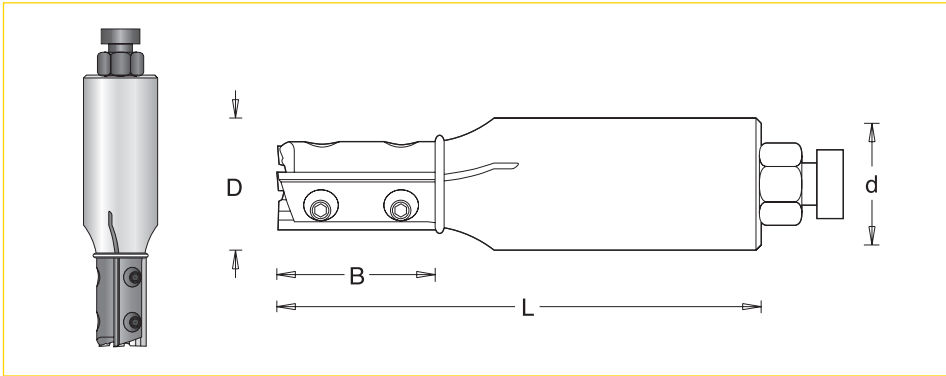
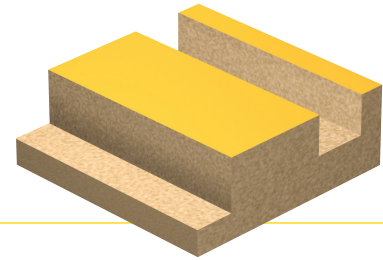

Disposable insert straight router cutter complete with a various number of flutes. Suitable for grooving, rebating and sizing in man-made boards (with or without coating). Replaceable inserts ensure a constant cutting diameter and finish quality. For use on routers and machining centres with CNC control. These cutters are not suitable for plunge cutting.



$\varnothing D$	Product Ref.	B	No. of blades	L	$\varnothing d$	n
10	IT/807 105 9* +	20	1	71.5	12	18,000
12	IT/807 111 9** +	30	2	81.0	12	18,000
16	IT/807 115 0 +	30	2	81.0	16	18,000
16	IT/807 116 0 +	50	2	101.0	16	18,000
18	IT/807 120 0	30	3	81.5	18	18,000
18	IT/807 120 H	30	3	81.5	25	18,000
18	IT/807 121 0	50	3	101.5	20	18,000
18	IT/807 121 0L ▲	50	3	101.5	20	18,000
18	IT/807 121 H	50	3	101.5	25	18,000
18	IT/807 121 HL ▲	50	3	101.5	25	18,000
20	IT/807 123 0	30	3	81.5	20	18,000
20	IT/807 125 0	50	3	101.5	20	18,000
20	IT/807 125 H	50	3	101.5	25	18,000
20	IT/807 125 HL ▲	50	3	101.5	25	18,000

▲ L=Left Hand Rotation.
+ Cutters do not have screw adjuster.

Spare Parts

Description	 T.C. Blade			 Hex Screw*	 Hex Screw**	 Hex Screw	 Hex Key
Product Ref.	IT/310 751 0/10	IT/310 751 1/10	IT/310 751 3/10	IT/193 035 0	IT/193 036 0	IT/193 037 0	IT/194 102 0
Size	20x5.5x1.1 (B = 20)	30x5.5x1.1 (B = 30)	50x5.5x1.1 (B = 50)	M3x4	M3x5	M3x7	S1.5

Blades sold in packs of ten.

