

### Solid Carbide Spiral Cutters for Lock Casing

Solid tungsten carbide router cutter complete with three spiral chip breaker flutes. Suitable for producing deep grooves, slots and holes for door furniture in softwood, hardwood, solid and hollow board doors. Solid carbide for maximum durability in abrasive materials. For use on routers and machining centres with CNC control.

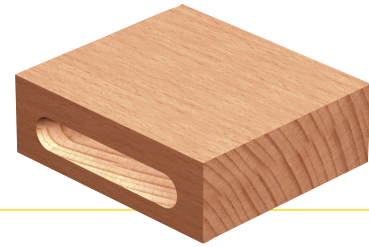

$\varnothing D$	Product Ref.	B1	B2	L	$\varnothing d$	n
14	IT/178 640 0	45	95	150	14	18,000
16	IT/178 646 0	45	115	170	16	18,000
18	IT/178 652 0	45	115	170	18	18,000

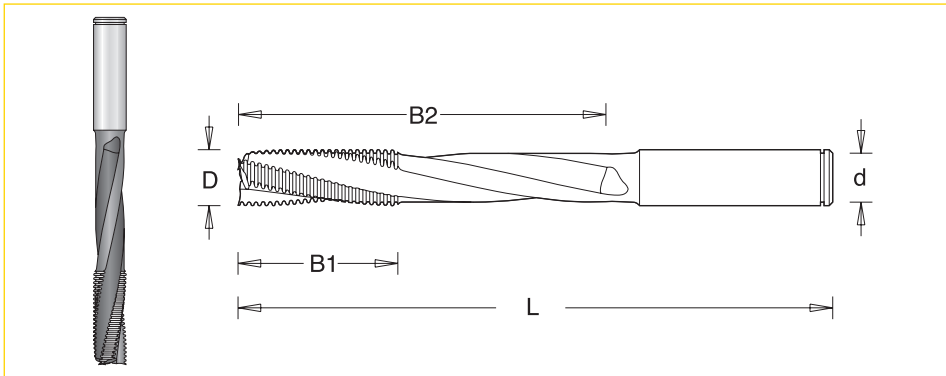

### Disposable Insert Router Cutters for Lock Casing

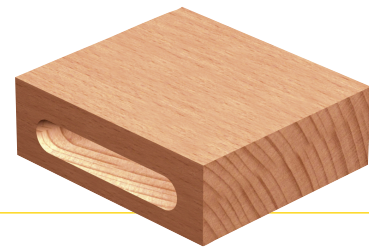
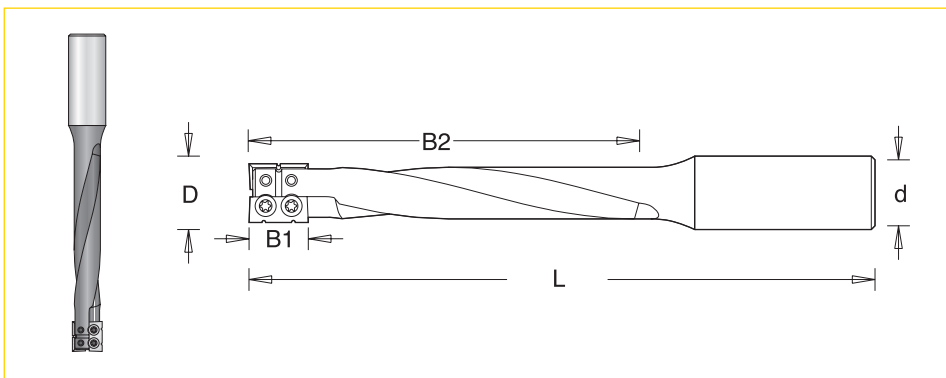

Disposable insert router cutter complete with two chip breaker flutes. Suitable for producing deep grooves, slots and holes for door furniture in softwood, hardwood, solid and hollow board doors. Replaceable inserts ensure a constant cutting diameter and finish quality. For use on routers and machining centres with CNC control.



$\varnothing D$	Product Ref.	B1	B2	L	$\varnothing d$	n
14	IT/807 360 0▲	16	95	150	20	12,000
16	IT/807 365 0▲	16	115	170	20	12,000
18	IT/807 370 0▲	16	115	170	20	12,000

▲While stocks last.

### Spare Parts

Description	 T.C. Blade	 Torx® Screw	 Torx® Key
Product Ref.	IT/310 771 6/10	IT/310 772 6/10	IT/193 400 0
Size	16x7x1.5	16x7x1.5	M3x4

Blades sold in packs of ten.

