

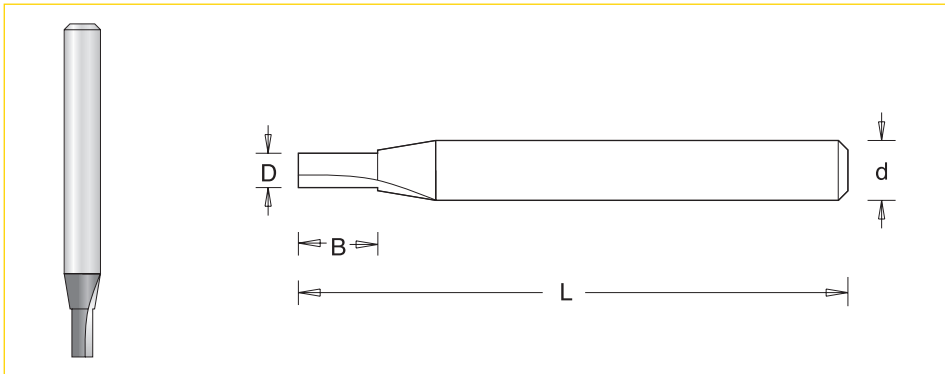

### Solid Carbide Straight Router Cutters - One Flute

Solid tungsten carbide router cutter complete with one or two straight flutes. Suitable for producing grooves and slots in softwood, hardwood or man-made boards. **DYNAMIC** carbide for maximum durability in abrasive materials and better plunge characteristics. Single flute for faster feed rate, two flute for improved finish. For use on routers and machining centres with or without CNC control.

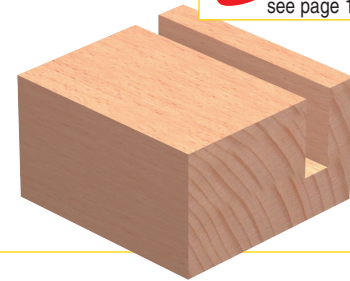

øD mm	øD ins	Product Ref.	B	L	ød
6.3	1/4	S2/6X1/4TC	10	-	1/4"
6.3	1/4	S2/60X1/4TC	19	-	1/4"

### Solid Carbide Straight Router Cutter - Two Flute

øD mm	øD ins	Product Ref.	B	L	ød
3	-	IT/S0107 001 3	11	60	6mm
4	-	IT/S0107 004 3	11	60	6mm
5	-	IT/S0107 007 3	11	60	6mm
6	-	IT/S0107 010 3	19	60	6mm
6	-	IT/S0107 013 3	25	60	6mm
6.3	1/4	S3/12X1/4STC	11	51	1/4"
6.3	1/4	S3/22X1/4STC	25	50	1/4"
6.3	1/4	S3/21X1/4STC	28	63	1/4"
8	-	IT/S0107 025 5	25	70	8mm
9.5	3/8	S3/50X3/8STC	25	63	3/8"
10	-	IT/S0107 858 7	30	80	10mm
12.7	1/2	S3/81X1/2STC	32	77	1/2"