

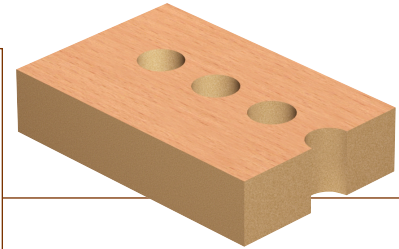

201 V-Point Through Hole Drill

Tungsten carbide tipped dowel drill with V drill point. Suitable for drilling tear free through holes in natural wood and man-made boards (including paper/plastic coated and veneered). Drills have a cylindrical shank with flat and length adjusting screw. For use on automatic and point-to-point boring machines.

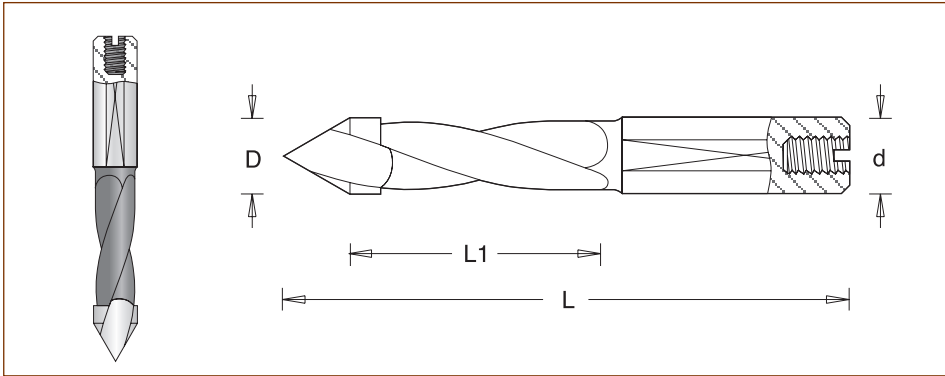

57.5mm Overall Length

øD	Product Ref.		L1	L	ød
	Right	Left			
4.0	IT/201 600 7	IT/201 601 7	25	57.5	10x25
5.0	IT/201 604 7	IT/201 605 7	25	57.5	10x25
6.0	IT/201 606 7	IT/201 607 7	25	57.5	10x25
7.0	IT/201 650 7	IT/201 651 7	25	57.5	10x25
8.0	IT/201 608 7	IT/201 609 7	25	57.5	10x25
9.0	IT/201 656 7	IT/201 657 7	25	57.5	10x25
10.0	IT/201 612 7	IT/201 613 7	25	57.5	10x25

 Screw
IT/193 000 0
M5x10

70mm Overall Length

øD	Product Ref.		L1	L	ød
	Right	Left			
5.0	IT/201 614 7	IT/201 615 7	40	70	10x25
6.0	IT/201 616 7	IT/201 617 7	40	70	10x25
7.0	IT/201 661 7	IT/201 662 7	40	70	10x25
8.0	IT/201 618 7	IT/201 619 7	40	70	10x25
9.0	IT/201 667 7	IT/201 668 7	40	70	10x25
10.0	IT/201 622 7	IT/201 623 7	40	70	10x25

 Screw
IT/193 000 0
M5x10

77mm Overall Length

øD	Product Ref.		L1	L	ød
	Right	Left			
5.0	IT/201 624 7	IT/201 625 7	45	77	10x25
6.0	IT/201 626 7	IT/201 627 7	45	77	10x25
7.0	IT/201 631 7	IT/201 632 7	45	77	10x25
8.0	IT/201 628 7	IT/201 629 7	45	77	10x25
9.0	IT/201 637 7	IT/201 638 7	45	77	10x25
10.0	IT/201 641 7	IT/201 642 7	45	77	10x25

 Screw
IT/193 000 0
M5x10

