

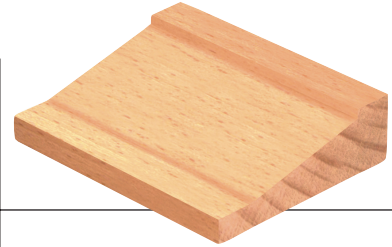

Disposable Insert Frame Profile Cutter

Cutter in hard wearing aluminium, complete with two disposable tungsten carbide knives. Suitable for profiling door edges in softwood, hardwood and man-made boards on a spindle moulder. Same tool body accepts all five different profiles. Recommended RPM 4,200 - 7,400.

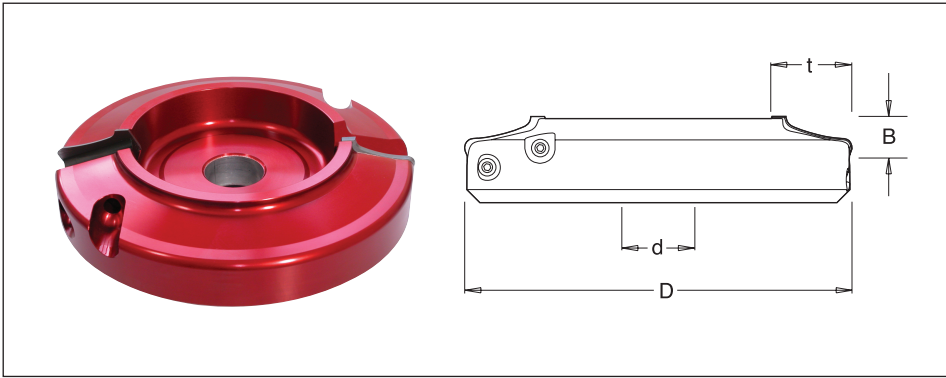

Profile	øD	B	Product Ref.	Max.t	ød
A	180	40	IT/751 012 1	30	30
B	180	40	IT/751 013 1	30	30
C	180	40	IT/751 014 1	30	30
D	180	40	IT/751 015 1	30	30
E	180	40	IT/751 016 1	30	30
Set	180	40	IT/751 011 1 (Set)	30	30

Profile	øD	B	Product Ref.	Max.t	ød
A	180	40	IT/751 012 7	30	1 1/4"
B	180	40	IT/751 013 7	30	1 1/4"
C	180	40	IT/751 014 7	30	1 1/4"
D	180	40	IT/751 015 7	30	1 1/4"
E	180	40	IT/751 016 7	30	1 1/4"
Set	180	40	IT/751 011 7 (Set)	30	1 1/4"

Spare Parts

Desc.	T.C. Blade					Wedge	Set Screw	Torx® Screw	Hex Key	Torx® Key
Product Ref.	IT/310 852 5	IT/310 852 6	IT/310 852 7	IT/310 852 8	IT/310 852 9	IT/199 070 0	IT/193 026 5	IT/193 395 0	IT/194 003 5	IT/194 101 5
Size	40x20x1.5	40x20x1.5	40x20x1.5	40x20x1.5	40x20x1.5	L=38	M6x16	M4x6	S3	T15

Blades sold in singles.

