

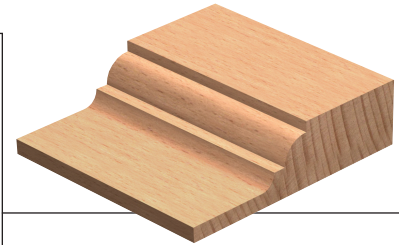

Tungsten Carbide Tipped Panel Raising Cutterhead

Cutterhead in hard wearing steel, complete with three tungsten carbide tips and ball bearing guide. Suitable for producing raised panel profiles in softwood, hardwood and man-made boards on a spindle moulder.

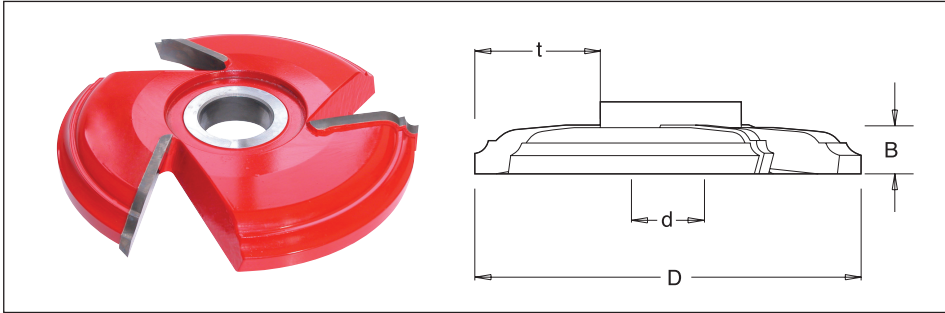

Hand Feed

øD	B	Product Ref.	Max. t	ød	n
153	19	IT/711 009 1	50	30	5,200 - 9,000

Accessory

Description	Ball Bearing
Product Ref.	IT/191 023 0
Size	55x30x13

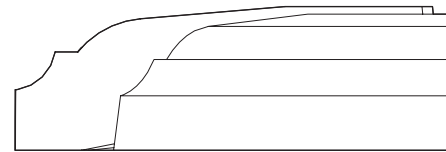
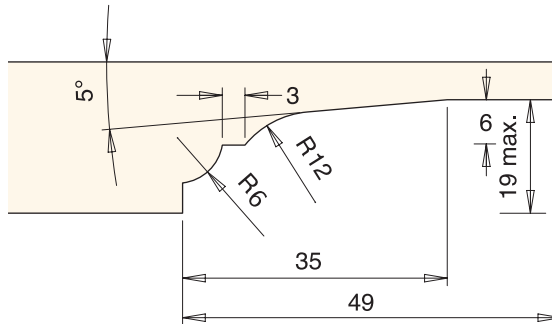

Disposable Insert Panel Raising Cutterhead

Cutterhead in hard wearing aluminium, complete with disposable tungsten carbide knives. Suitable for producing raised panel profiles in softwood, hardwood and man-made boards on a spindle moulder.

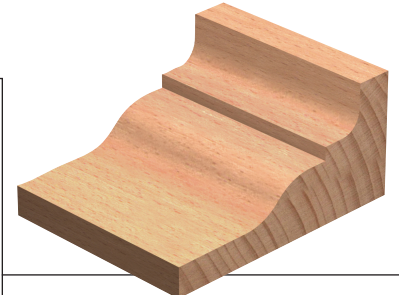
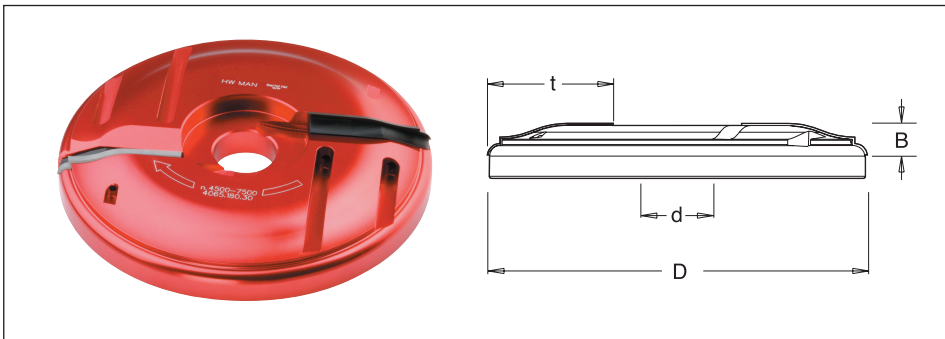

Hand Feed



EN847-1/2

øD	B	Product Ref.	d	Max. t	n
180	25	IT/751 008 1	30	57	4,500 - 7,500
180	25	IT/751 008 7	1 1/4"	57	4,500 - 7,500

Spare Parts

Description	T.C. Blade	Wedge	Set Screw	Hex Key
Product Ref.	IT/310 853 9	IT/199 049 0	IT/193 026 5	IT/194 003 5
Size	60x16x2	L=57.5	M6x16	S3

Blades sold in singles.

