

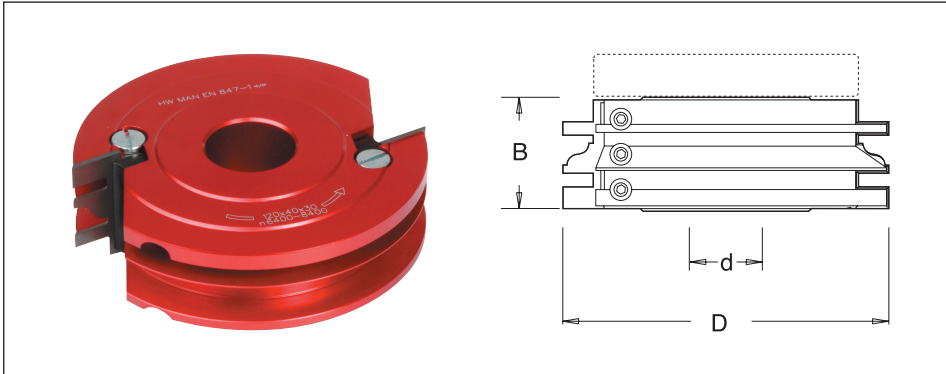

Disposable Insert Profile - Counter Profile Cutter Blocks

Cutterhead in hard wearing aluminium, complete with disposable tungsten carbide knives. Suitable for producing various profile / counter profile joints in softwood, hardwood and man-made boards on a spindle moulder. Raising or lowering the cutter on the spindle moulder produces both parts of the joint. Same tool body accepts all four different profiles.

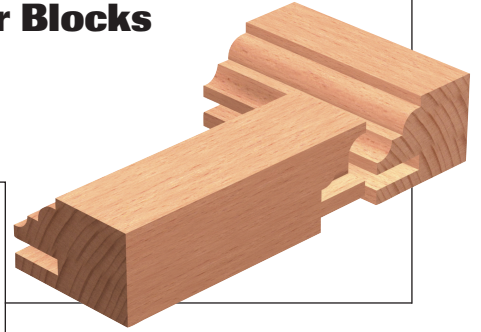

Hand Feed



EN847-1/2



øD	B	Product Ref.	Profile	ød	n
120	40	IT/742 031 1	1	30	5,000 - 8,400
120	40	IT/742 032 1	2	30	5,000 - 8,400
120	40	IT/742 033 1	3	30	5,000 - 8,400
120	40	IT/742 034 1	4	30	5,000 - 8,400



øD	B	Product Ref.	Profile	ød	n
120	40	IT/742 031 7	1	1 1/4"	5,000 - 8,400
120	40	IT/742 032 7	2	1 1/4"	5,000 - 8,400
120	40	IT/742 033 7	3	1 1/4"	5,000 - 8,400
120	40	IT/742 034 7	4	1 1/4"	5,000 - 8,400



Spare Parts



Cutter 1	T.C. Blade				Wedge	Set Screw	Hex Key	Ball Bearing
Description	T.C. Blade				Wedge	Set Screw	Hex Key	Ball Bearing
Product Ref.	IT/310 865 6 Profile 1	IT/310 866 6 Profile 2	IT/310 867 6 Profile 3	IT/310 868 6 Profile 4	IT/199 042 5	IT/193 026 5	IT/194 003 5	IT/191 520 1
Size	40x26x2	40x26x2	40x26x2	40x26x2	L=38	M6x16	S3	98x15x30



Blades sold in singles.
3 max.

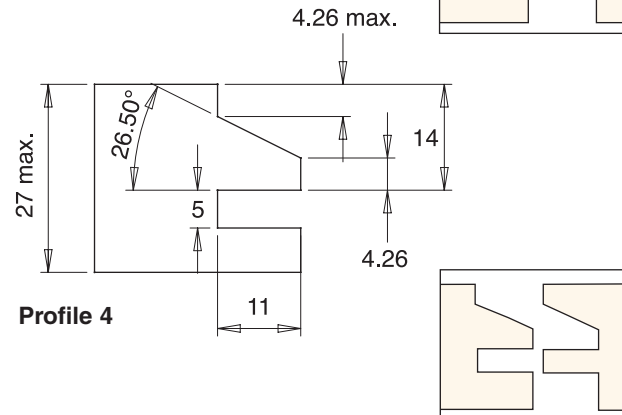
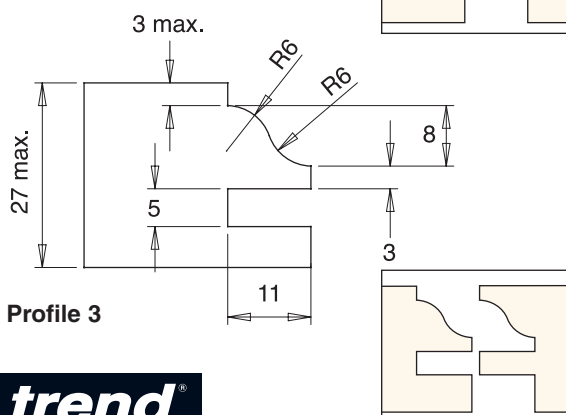
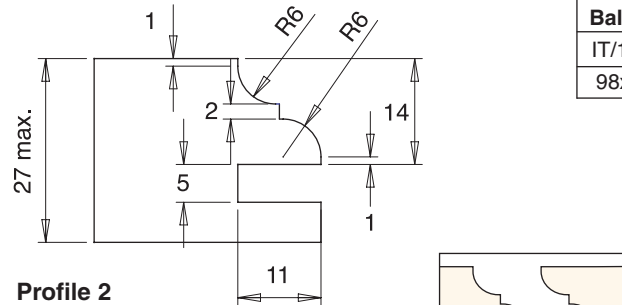
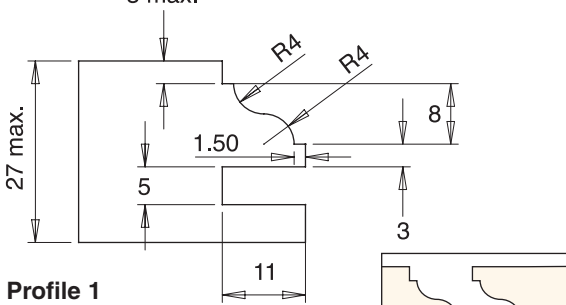

Ball Bearing
IT/191 520 7
98x15x1 1/4"