

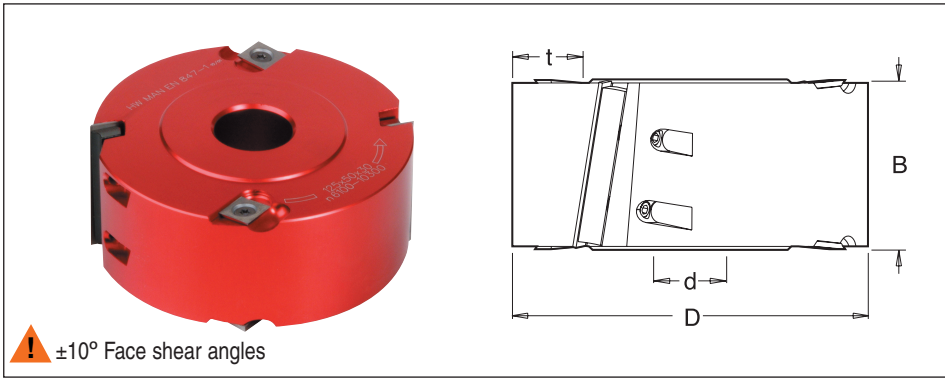

Disposable Insert Shear Rebating Cutter Blocks

Cutterhead bodies available in hard wearing aluminium or steel, complete with shear angle disposable tungsten carbide knives and scorers. Suitable for producing various thickness rebates in softwood, hardwood and man-made boards (with or without coating) on a spindle moulder. Shear angle reduces tear out and improve quality of cut.

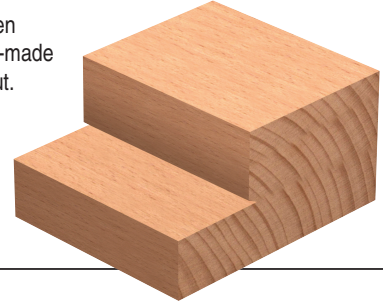

Hand Feed



EN847-1/2

øD	B	Product Ref.	Teeth	ød	Max. t	n
125	30	IT/733 001 1	4+4	30	27	6,100 - 10,300
125	30	IT/733 001 7	4+4	1 1/4"	27	6,100 - 10,300
125	50	IT/733 004 1*	2+4	30	27	6,100 - 10,300
125	50	IT/733 004 7*	2+4	1 1/4"	27	6,100 - 10,300
125	50	IT/733 002 1	4+4	30	27	6,100 - 10,300
125	50	IT/733 002 7	4+4	1 1/4"	27	6,100 - 10,300
125	60	IT/733 005 1*	2+4	30	27	6,100 - 10,300
125	60	IT/733 005 7*	2+4	1 1/4"	27	6,100 - 10,300
150	60	IT/733 006 1*	2+4	30	40	5,200 - 8,600
150	60	IT/733 006 7*	2+4	1 1/4"	40	5,200 - 8,600

! * Aluminium body

Spare Parts

Description	T.C. Blade			Wedge			T.C. Blade	Torx® Screw
Product Ref.	IT/310 123 0/10 B=30mm	IT/310 125 0/10 B=50mm	IT/300 053 1/10	IT/199 027 5 B=60mm	IT/199 045 0 B=30mm	IT/199 033 6 B=50mm	IT/300 850 3/10 B=60mm	IT/193 370 0
Size	30x12x1.5	50x12x1.5	60x12x1.5	L=26	L=46	L=56	14x14x2	M5x6.3
Description	Set Screw		Torx® Key	Hex Key	Set Gauge			
Product Ref.	IT/193 026 5 B=30&60	IT/193 065 0 B=50	IT/194 106 0	IT/194 003 5	IT/760 105 5			
Size	M6x16	M6x10	T20	S3	0.55mm			

Blades sold in packs of ten.