

Adjustable Grooving and Rebating Cutters with Scorers 25-49.5mm

Hard wearing steel body complete with tungsten carbide knives and scorers for improved finish. Suitable for producing various thickness grooves and rebates in softwood, hardwood and man-made boards (with or without coating) on a spindle moulder. Cutting width can be adjusted in 0.1mm steps by using supplied spacer rings.

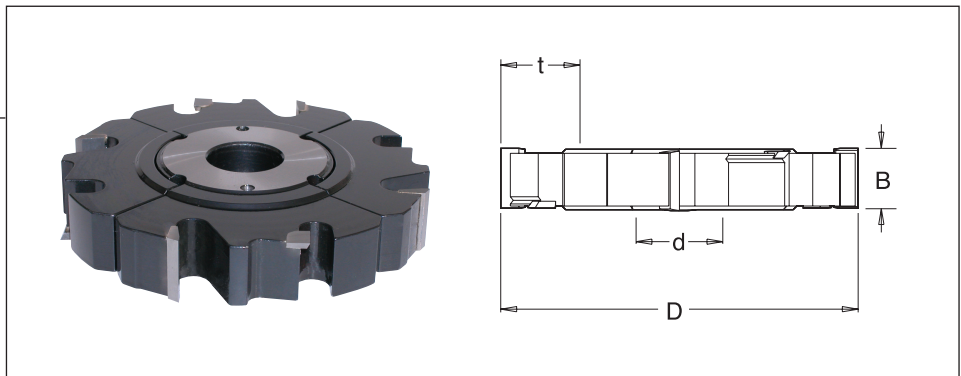

$\varnothing D$	B min-max	Product Ref.	Teeth	$\varnothing d$	Max. t	n
150	25.0-49.5	IT/797 110 1	4+4	30	27	5,200 - 9,000

Spare Parts

Description	Spacer Set
Product Ref.	IT/797 310 1 B=26.1

