

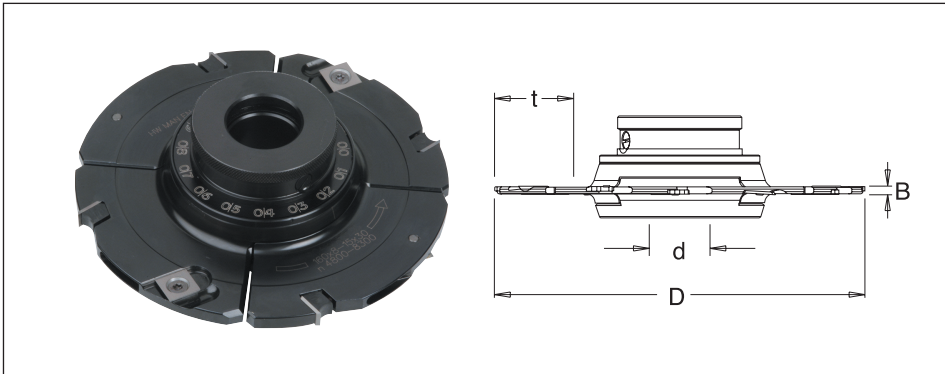

Disposable Insert Adjustable Grooving Cutters with Scorers and Ring Nut 4-7.5mm

Hard wearing steel body complete with disposable tungsten carbide knives and scorers for improved finish. Suitable for producing various thickness grooves and slots in softwood, hardwood and man-made boards (with or without coating) on a spindle moulder. Cutting width can be adjusted in 0.1mm steps by special threaded bush and scale without removing the cutter from the spindle.

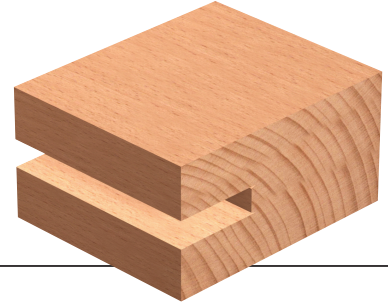

Hand Feed



EN847-1/2

øD	B	Product Ref.	Teeth	ød	Max. t	n
160	4.0-7.5	IT/722 016 1	8+4	30	30	4,800 - 8,300
160	4.0-7.5	IT/722 016 7	8+4	1 1/4"	30	4,800 - 8,300
180	4.0-7.5	IT/722 017 1	8+4	30	40	4,300 - 7,500
180	4.0-7.5	IT/722 017 7	8+4	1 1/4"	40	4,300 - 7,500

Spare Parts

Description	T.C. Blade	T.C. Blade	T.C. Blade Nut	Torx® Screw	Torx® Key	
Product Ref.	IT/300 850 1/10	IT/300 850 2/10	IT/192 350 0	IT/192 360 0	IT/193 028 0	IT/194 110 0
Size	18x18x2	14x14x2	M4x0.5x11.1	M4x0.5x9.9	M4x3.2	T9

Blades sold in packs of ten.

Disposable Insert Adjustable Grooving Cutters with Scorers and Ring Nut 8-24mm

øD	B	Product Ref.	Teeth	ød	Max. t	n
160	8.0-15.0	IT/722 008 1	4+4	30	30	4,800 - 8,300
160	8.0-15.0	IT/722 008 7	4+4	1 1/4"	30	4,800 - 8,300
160	12.5-24.0	IT/722 009 1	4+4	30	30	4,800 - 8,300
160	12.5-24.0	IT/722 009 7	4+4	1 1/4"	30	4,800 - 8,300
180	8.0-15.0	IT/722 011 1	4+4	30	40	4,800 - 7,500
180	8.0-15.0	IT/722 011 7	4+4	1 1/4"	40	4,800 - 7,500
180	12.5-24.0	IT/722 012 1	4+4	30	40	4,800 - 7,500
180	12.5-24.0	IT/722 012 7	4+4	1 1/4"	40	4,800 - 7,500

Spare Parts

Desc.	T.C. Blade	Wedge	T.C. Blade	Torx® Screw	Set Screw	Torx® Key	Hex Key	Set Gauge		
Product Ref.	IT/310 751 2/10 B=8-15mm	IT/300 750 9/10 B=12.5-24mm	IT/199 031 0 B=8-15mm	IT/199 032 0 B=12.5-24mm	IT/300 850 3/10	IT/193 370 0	IT/193 060 0	IT/194 106 0	IT/194 008 0	IT/760 102 5
Size	7.5x12x1.5	11.6x12x1.5	L=6.5	L=10.5	14x14x2	M5x6.3	M5x16	T20	S2.5	0.25mm

Blades sold in packs of ten.