

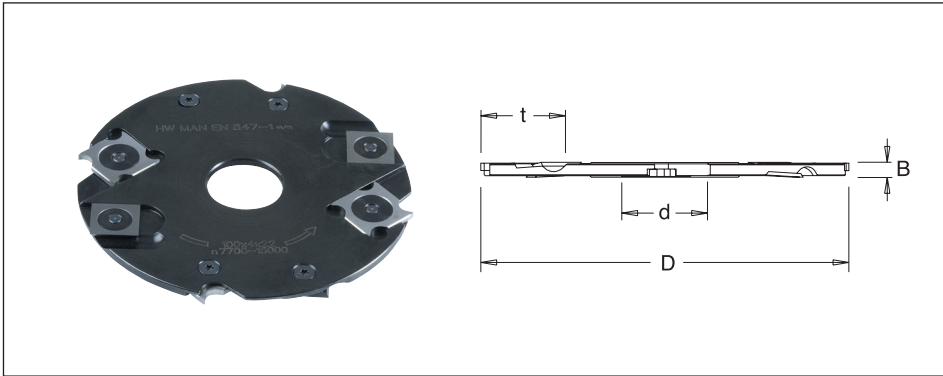

## Disposable Insert Grooving Cutters with Scorers 4-6mm

Hard wearing steel body complete with disposable tungsten carbide knives and scorers for improved finish. Suitable for producing grooves and slots in softwood, hardwood and man-made boards (with or without coating) on a spindle moulder. Can be used with spacer rings (see page 106) for comb jointing.

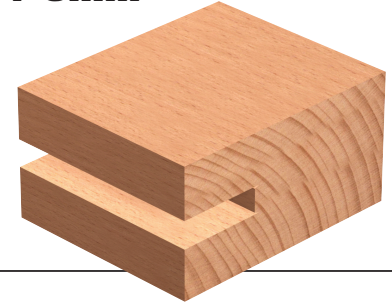

Hand Feed





EN847-1/2

øD	B	Product Ref.	Teeth	ød	Max. t	n
125	4	IT/721 001 1	4+4	30	35	6,100 - 10,500
125	5	IT/721 002 1	4+4	30	35	6,100 - 10,500
125	6	IT/721 003 1	4+4	30	35	6,100 - 10,500
150	4	IT/721 004 1	4+4	30	45	5,200 - 8,900
150	4	IT/721 004 7	4+4	1 1/4"	45	5,200 - 8,900
150	5	IT/721 005 1	4+4	30	45	5,200 - 8,900
150	5	IT/721 005 7	4+4	1 1/4"	45	5,200 - 8,900
150	6	IT/721 006 1	4+4	30	45	5,200 - 8,900
150	6	IT/721 006 7	4+4	1 1/4"	45	5,200 - 8,900
180	4	IT/721 007 1	8+8	30	55	4,200 - 7,200
180	5	IT/721 008 1	8+8	30	55	4,200 - 7,200
180	6	IT/721 009 1	8+8	30	55	4,200 - 7,200

### Spare Parts



⚠ Tools above also available with a 1 1/4" bore, replace last digit with a 7.

Description	 T.C. Blade			 T.C. Blade		
	Product Ref.	IT/300 850 1/10	IT/300 850 4/10	IT/300 850 5/10	IT/300 850 2/10	IT/300 850 2/10
Size	18x18x2 (B=4mm)	18x18x2.5 (B=5mm)	18x18x2.95 (B=6mm)	14x14x1.2 (B=4mm)	14x14x1.2 (B=5mm)	14x14x1.2 (B=6mm)

Description	 T.C. Blade Nut					
	Product Ref.	IT/192 350 0	IT/192 350 0	IT/192 350 0	IT/192 360 0	IT/192 360 0
Size	M4x0.5x11.1 (B=4mm)	M4x0.5x11.1 (B=5mm)	M4x0.5x11.1 (B=6mm)	M4x0.5x9.9 (B=4mm)	M4x0.5x9.9 (B=5mm)	M4x0.5x9.9 (B=6mm)

Description	 Torx® Screw			 Torx® Key		
	Product Ref.	IT/193 028 0	IT/193 030 0	IT/193 031 0	IT/194 110 0	IT/194 110 0
Size	M4x3.2 (B=4mm)	M4x4 (B=5mm)	M4x5.3 (B=6mm)	T9 (B=4mm)	T9 (B=5mm)	T9 (B=6mm)

Blades sold in packs of ten.