

### Grooving Cutters 3-16mm

Hard wearing steel tool body complete with six tungsten carbide knives. Suitable for producing grooves and slots in softwood, hardwood and man-made boards (with or without coating) on a spindle moulder. Can be used with spacer rings (see page 106) for comb jointing.

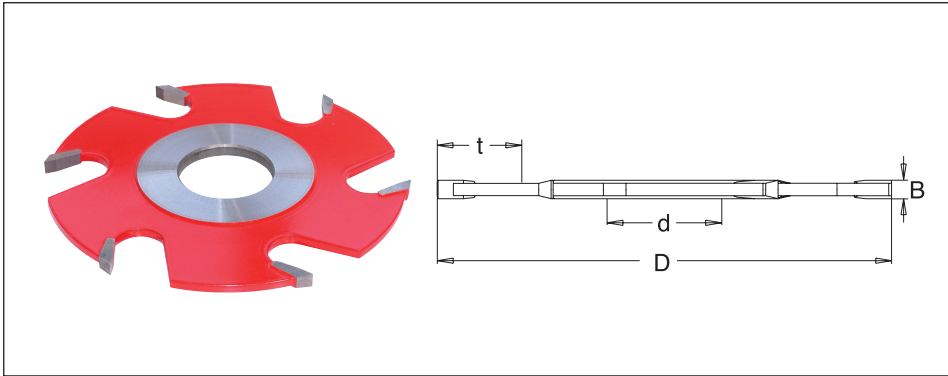
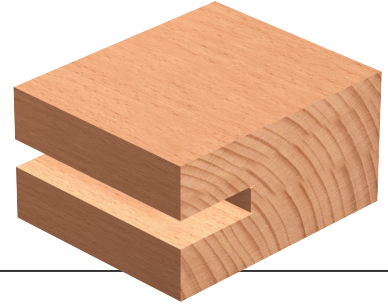

Hand Feed

$\varnothing D$	B	Product Ref.	Teeth	$\varnothing d$	Max. t	n
125	3	IT/707 001 1	6	30	32	6,100 - 10,500
125	4	IT/707 004 1	6	30	32	6,100 - 10,500
125	5	IT/707 007 1	6	30	32	6,100 - 10,500
125	6	IT/707 010 1	6	30	32	6,100 - 10,500
125	8	IT/707 013 1	6	30	32	6,100 - 10,500
125	10	IT/707 016 1	6	30	32	6,100 - 10,500
125	12	IT/707 019 1	6	30	32	6,100 - 10,500
125	14	IT/707 022 1	6	30	32	6,100 - 10,500
125	16	IT/707 025 1	6	30	32	6,100 - 10,500
150	4	IT/707 031 1	6	30	45	5,200 - 9,000
150	5	IT/707 034 1	6	30	45	5,200 - 9,000
150	6	IT/707 037 1	6	30	45	5,200 - 9,000
150	8	IT/707 040 1	6	30	45	5,200 - 9,000
150	10	IT/707 043 1	6	30	45	5,200 - 9,000
150	12	IT/707 046 1	6	30	45	5,200 - 9,000
150	14	IT/707 049 1	6	30	45	5,200 - 9,000
150	16	IT/707 052 1	6	30	45	5,200 - 9,000
180	5	IT/707 055 1	8	30	60	4,300 - 7,500
180	6	IT/707 058 1	8	30	60	4,300 - 7,500

⚠ Also available with a 1 1/4" bore, replace last digit with a 7.

