

**INDUSTRIAL SAWBLADES**

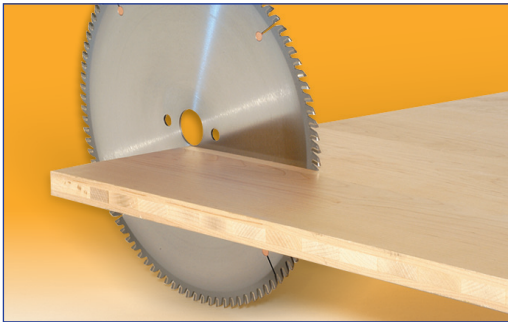

### Rip & Cross Cut Sawblades

Alternate bevel sawblade for rip and cross cutting with a coarse/medium finish on solid soft and hard woods. Suitable for use on a table saw.

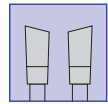

**Solid Wood**  
**Alternate Bevel**  
**Coarse/Medium Finish**

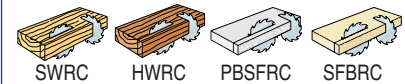
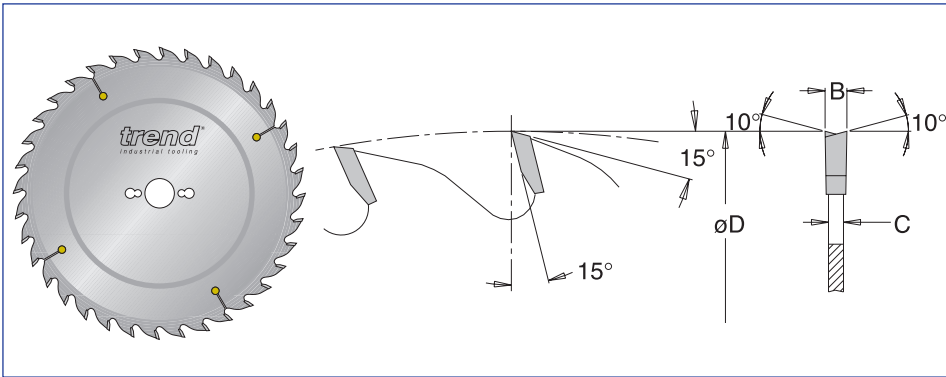

øD	Teeth	Product Ref.	B	C	ø bore
250	30	IT/901 01 60 6	3.2	2.2	30
300	36	IT/901 01 70 6	3.2	2.2	30
350	36	IT/901 01 79 6	3.5	2.5	30
350	42	IT/901 01 80 6	3.5	2.5	30
400	48	IT/901 01 90 6	3.5	2.5	30
450	54	IT/901 02 00 6	4.0	2.8	30
500	60	IT/901 02 05 6	4.4	3.0	30

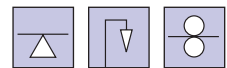

### Ripping & Cross Cut Sawblade

Four alternate bevel and one flat tooth sawblade for rip and crosscutting with a coarse/medium finish on solid soft and hardwoods. Large gullets in the saw body allow for deeper cuts and improve chip removal.

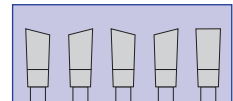

**Solid Wood**  
**Alternate Bevel/Flat**  
**Coarse/Medium Finish**

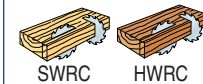
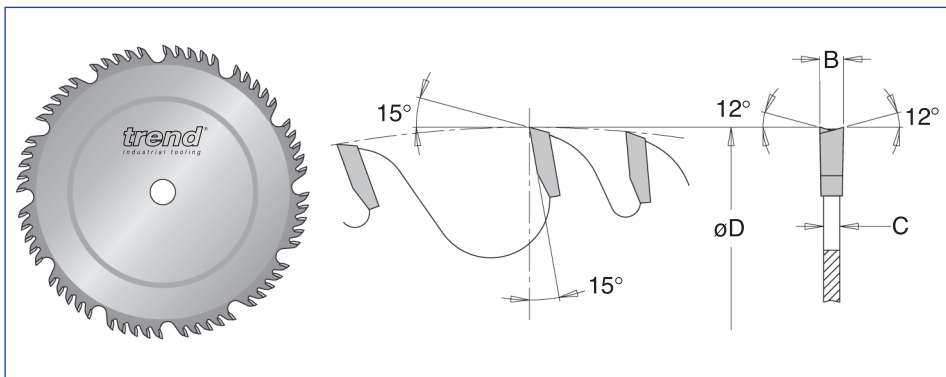

øD	Teeth	Product Ref.	B	C	ø bore
250	40	IT/908 00 30 6	3.4	2.4	30
250	50	IT/908 00 40 6	3.4	2.4	30
300	60	IT/908 00 50 6	3.8	2.8	30
350	70	IT/908 00 60 6	3.8	2.8	30
400	80	IT/908 00 70 6	4.0	3.0	30

