

### Rip Sawblades

Flat tooth sawblade for rip cutting with a coarse finish on solid soft and hard woods. Anti-kick back, chip limiter design and cooling slots for continuous use. Suitable for use on a table saw or multiple rip saw.

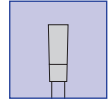

**Solid Wood**  
**Flat**  
**Coarse Finish**

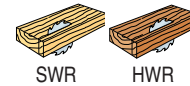
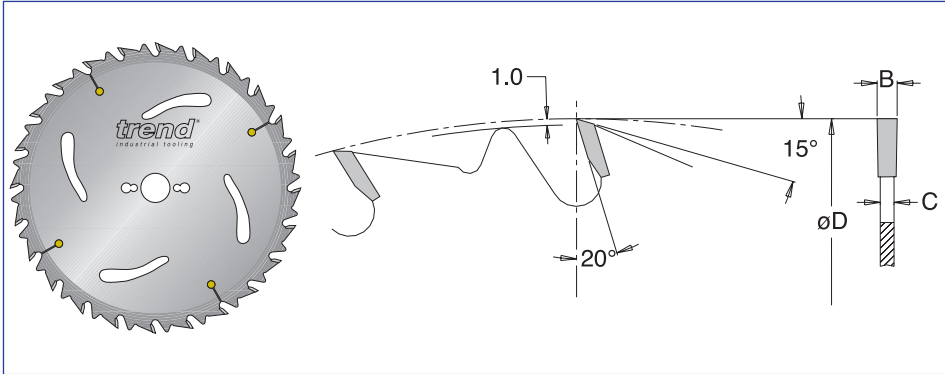

øD	Teeth	Product Ref.	B	C	keyways	ø bore
250	20	IT/901 00 90 6	3.2	2.2	-	30
250	24	IT/901 00 95 6	3.2	2.2	-	30
300	14	IT/901 00 97 6	3.2	2.2	-	30
300	24	IT/901 01 00 6	3.2	2.2	-	30
300	24	IT/901 01 00 0	3.2	2.2	2/20x6	70
300	28	IT/901 01 04 6	3.2	2.2	-	30
300	28	IT/901 01 04 0	3.2	2.2	2/20x6	70
315	24	IT/901 01 08 6	3.2	2.2	-	30
350	16	IT/901 01 07 6	3.5	2.5	-	30
350	28	IT/901 01 10 6	3.5	2.5	-	30
350	32	IT/901 01 13 6	3.5	2.5	-	30
400	18	IT/901 01 14 6	3.5	2.5	-	30
400	28	IT/901 01 15 6	3.5	2.5	-	30
450	40	IT/901 01 16 6	4.0	2.8	-	30
500	44	IT/901 01 18 6	4.4	3.0	-	30

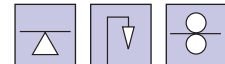

### Rip Sawblades

Flat tooth sawblade for rip and cross cutting with a coarse finish on solid soft and hard woods. Anti-kick back, chip limiter design and Tungsten Carbide wiper slots for continuous heavy-duty use, particularly in wet wood. Suitable for use on a table saw or multiple rip saw.

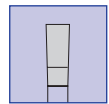

**Solid Wood**  
**Flat**  
**Coarse Finish**

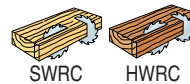
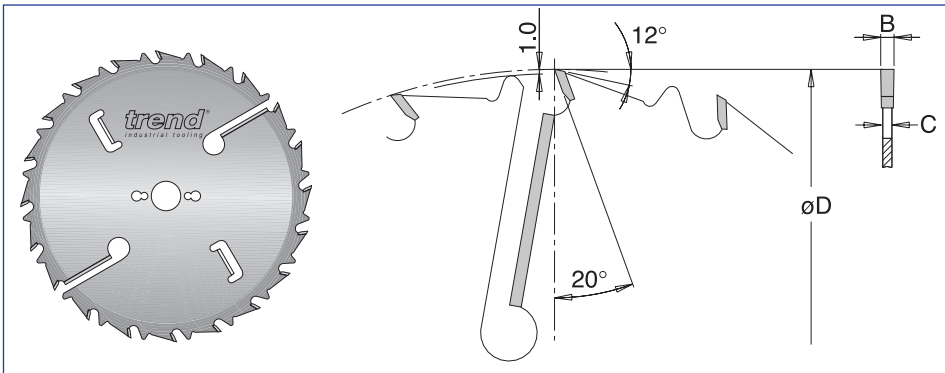

øD	Teeth	Product Ref.	B	C	ø bore
300	20+2+2	IT/904 00 35 6	3.2	2.2	30
350	24+2+2	IT/904 00 55 6	3.5	2.5	30

Suitable for cutting wet wood.

