

MULTI PROFILE ROUTER CUTTERS FOR 40MM & 50MM PROFILE KNIVES - TWO FLUTE

- Multi profile router cutter to take the complete range of 40mm and 50mm profile knives shown on pages 58 to 86.
- Suitable for producing profiles in softwood and hardwood.
- Supplied with rebate knives as standard.
- For use on routers and machining centres with CNC control.
- Recommended RPM (n): 12,000.

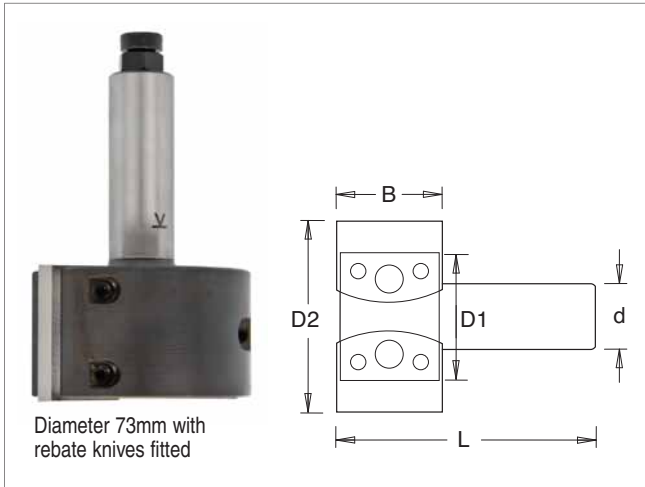

Diameter 73mm with rebate knives fitted

øD1	øD2	B	L	ød	Product Ref.	Stock	Price
66	73	40/50	90	20	IT/871 006 1	Y	£151.39
66	73	40/50	90	25	IT/871 006 0	Y	£151.39

SPARE PARTS

Desc.	Rebate Knife	Wedge	Set Screw	Hex Key
Prod. Ref.	IT/331 904 0	IT/199 802 0	IT/193 026 6	IT/194 003 6
Size	40x20x4	L=38	M8x12	S4
Price	£6.52	£10.43	£1.62	£5.22

PROFILE EXAMPLES

For the full range of available knives and limitors see pages 58 to 85.

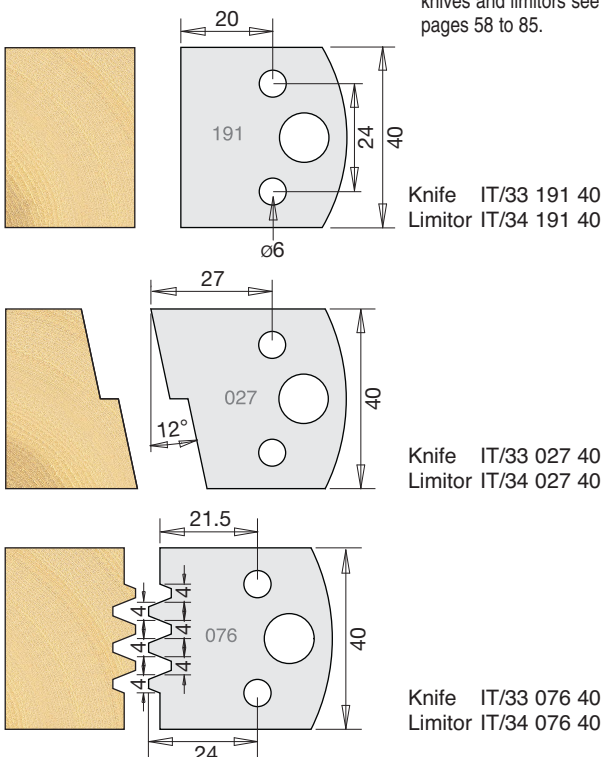

DISPOSABLE INSERT FINGER JOINT ROUTER CUTTER - TWO FLUTE

- Suitable for producing 8mm deep finger joints in softwoods, hardwoods and man-made boards.
- For use on routers and machining centres with CNC control.
- Recommended RPM (n): 12,000.

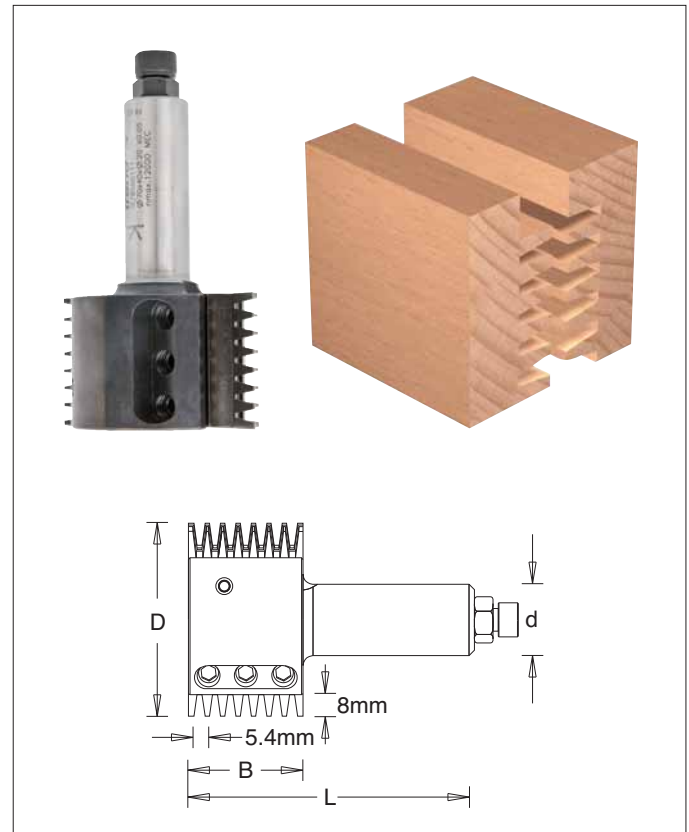

øD	B	L	ød	Product Ref.	Stock	Price
70	40	100	20	IT/856 011 1	Y	£343.48
70	40	100	25	IT/856 011 0	Y	£343.48

SPARE PARTS

Description	T.C. Blade	Backing Plate	Hex Screw
Product Ref.	IT/315 650 2	IT/199 110 1	IT/193 026 6
Size	40x28x1.5	40x22.5x4	M8x12
Price	£44.14	£18.78	£1.62

Wedge	Hex Key
IT/199 022 0	IT/194 015 0
40x13.5x8	S4
£9.43	£1.67

KEY

Stock - Y means normally kept in stock for next day delivery.
N means not normally held in stock, delivery in a short time.