

DISPOSABLE INSERT MULTI PURPOSE PROFILE ROUTER CUTTERS - TWO FLUTE

- Suitable for producing profiles in softwood, hardwood and man-made board.
- Tool will be supplied with standard inserts (profile 1 or 2), or can be supplied with special inserts, ground to the customer's own specification.
- Replaceable inserts ensure a constant cutting diameter and finish quality.
- For use on routers and machining centres with CNC control.
- Recommended RPM (n): 18,000.

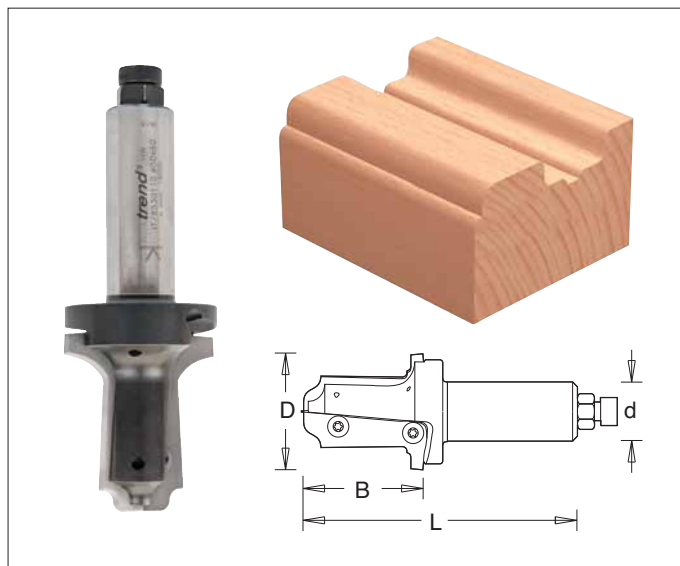

øD	B	Profile	L	ød	Product Ref.	Stock	Price
50	50	Special	120	20	Special *	N	Special
50	50	1	120	20	IT/853 011 0	Y	£241.67
50	50	2	120	20	IT/853 012 0	Y	£241.67

* Please contact our technical department on 01923 224681 for price & delivery on special profiles.

SPARE PARTS

Desc.	T.C. Blade Profile 1	T.C. Blade Profile 2	Torx® Screw	Torx® Key
Prod. Ref.	IT/315 300 1	IT/315 300 2	IT/193 395 0	IT/194 101 5
Size	54x20x2	54x20x2	M4x6	T15
Price	£36.42	£36.42	£1.62	£3.14

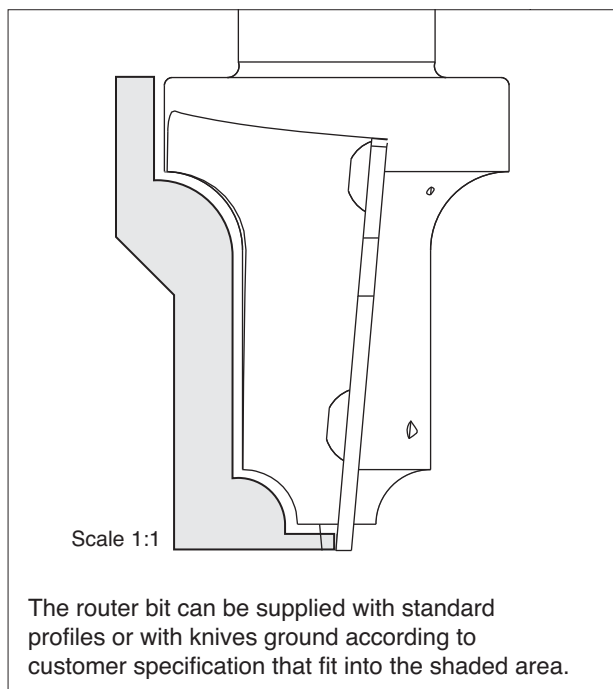

PROFILE 1

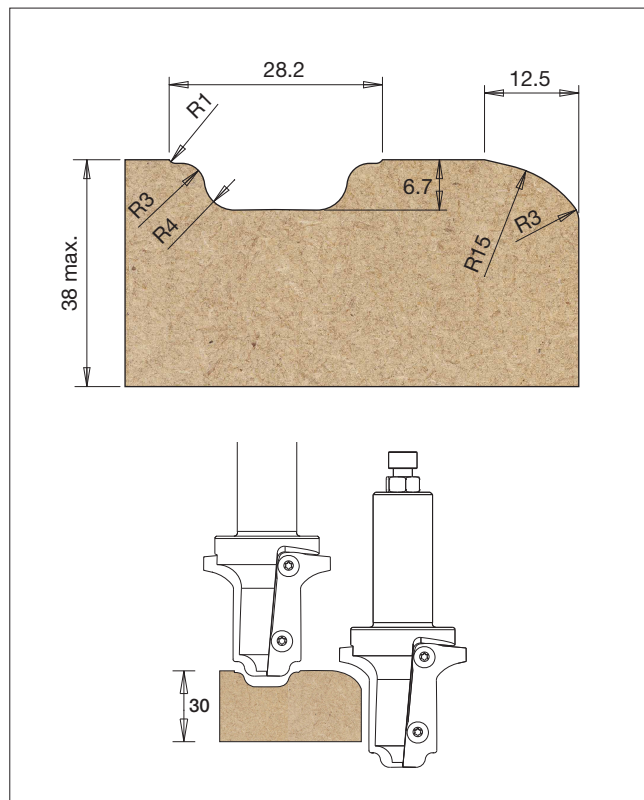

PROFILE 2

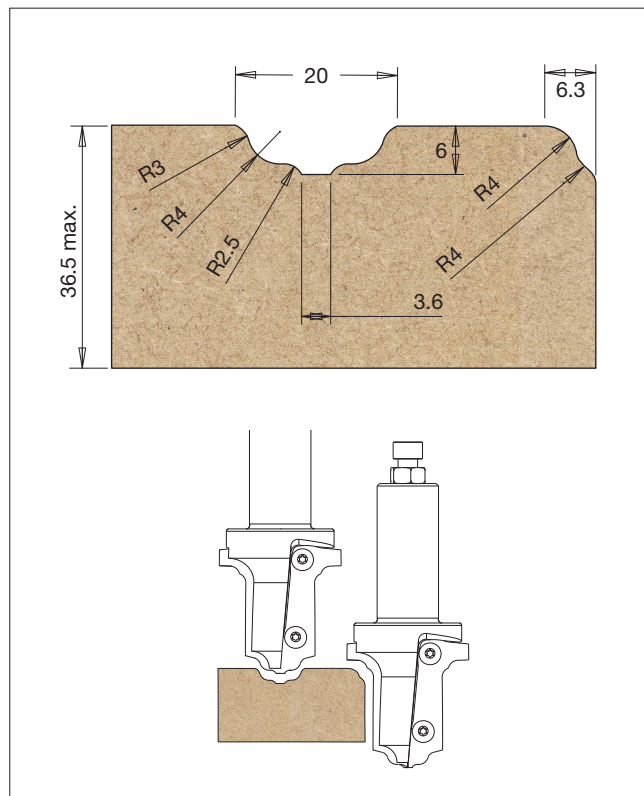

KEY

Spare Blades & Scorers - Product Reference ending in /10 are sold in packs of ten.
Stock - Y means normally kept in stock for next day delivery.
 N means not normally held in stock, delivery in a short time.