

DISPOSABLE INSERT STRAIGHT REBATING CUTTERS WITH SCORERS - TWO FLUTE

- Suitable for trimming and rebating in softwood, hardwood and man-made board.
- Scorers will give an improved finish at the bottom of the cut.
- Replaceable inserts ensure a constant cutting diameter and finish quality.
- For use on routers and machining centres with CNC control.
- Recommended RPM (n): 18,000.

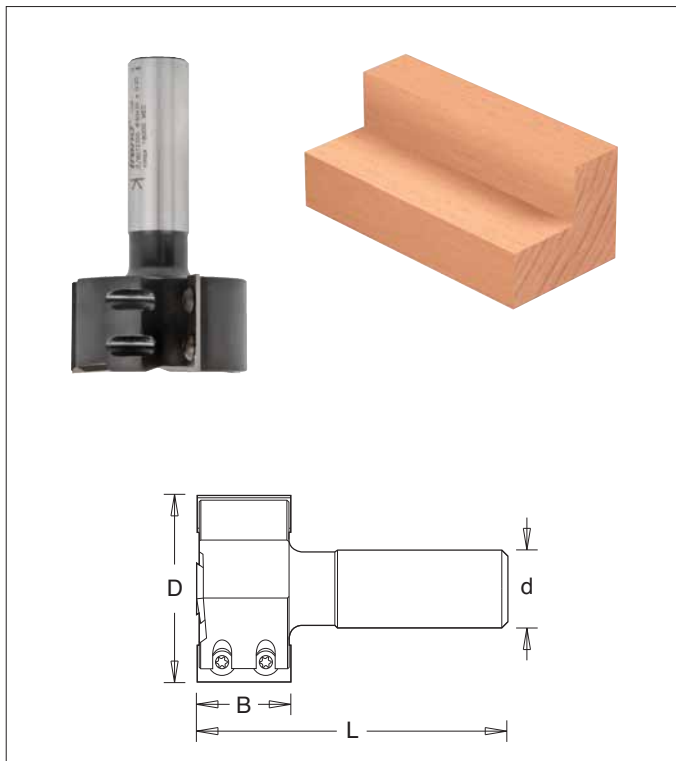

øD	B	L	ød	Product Ref.	Stock	Price
40	30	100	20	IT/807 330 0	Y	£198.16
60	30	100	20	IT/807 335 0	Y	£214.72
60	50	120	20	IT/807 337 0	N	£228.47

! Also available with 25mm diameter shank, replace the last digit with an 'H'.

SPARE PARTS

Description	T.C. Blade		T.C. Blade
Product Ref.	IT/310 123 0/10	IT/310 125 0/10	IT/300 850 3/10
Size	30x12x1.5	50x12x1.5	14x14x2
Price	£22.48	£33.96	£22.48

Torx® Screw		Torx® Key	
IT/193 148 1	IT/193 370 0	IT/194 101 5	IT/194 106 0
M4x5.6 (pan)	M5x6.3 (csk)	T15	T20
£1.61	£1.62	£3.14	£6.84

DISPOSABLE INSERT PLANING & REBATING ROUTER CUTTERS WITH SCORERS - TWO FLUTE

- Suitable for planing and rebating in softwood, hardwood & man-made board.
- A good tool for fast removal of material over a large surface area.
- Scorers will give an improved finish at the bottom of the cut.
- Replaceable inserts ensure a constant cutting diameter and finish quality.
- For use on routers and machining centres with CNC control.

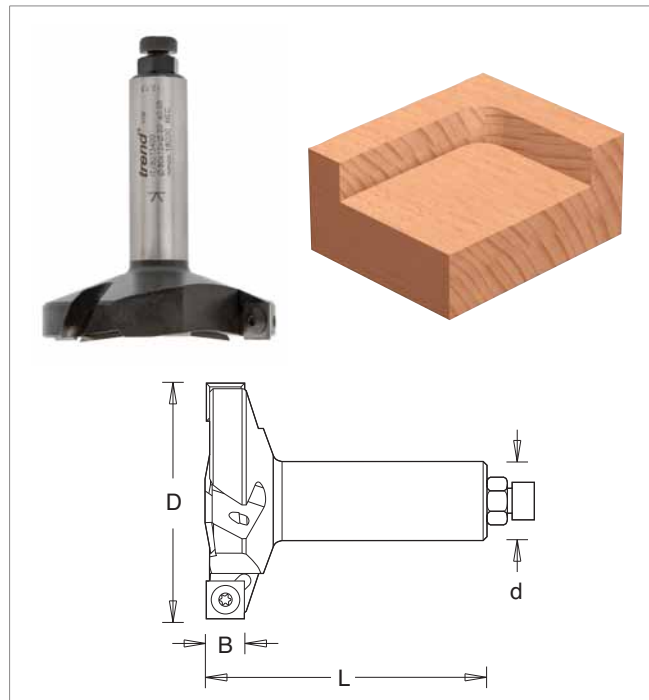

øD	B	L	ød	Product Ref.	Stock	Price
80	12	90	20	IT/807 340 0	Y	£171.74

SPARE PARTS

Description	T.C. Blade	
Product Ref.	IT/310 121 2/10	IT/300 850 3/10
Size	12x12x1.5	14x14x2.0
Price	£32.92	£22.48

Torx® Screw		Torx® Key	
IT/193 395 0	IT/193 370 0	IT/194 101 5	IT/194 106 0
M4x6	M5x6.3 (csk)	T15	T20
£1.62	£1.62	£3.14	£6.84

KEY

Spare Blades & Scorers - Product Reference ending in /10 are sold in packs of ten.

Stock - Y means normally kept in stock for next day delivery.

N means not normally held in stock, delivery in a short time.