

DISPOSABLE INSERT UP & DOWN SHEAR ROUTER CUTTERS - TWO FLUTE

- Shear flutes ensure a good finish on the top and bottom of laminated and veneered board.
- Suitable for softwood, hardwood and man-made board.
- Replaceable inserts ensure a constant cutting diameter and finish quality.
- Brazed centre tip for improved plunging.
- For use on routers and machining centres with CNC control.
- Recommended RPM (n): 18,000.

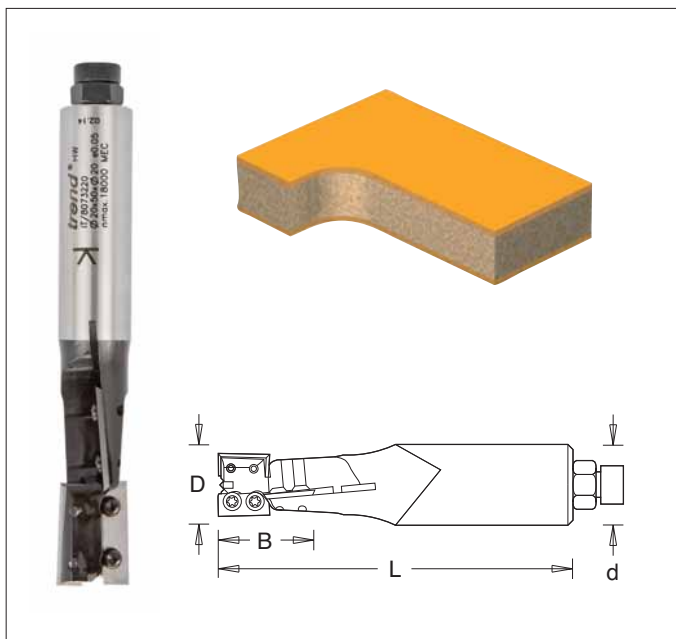

øD	B	L	ød	Product Ref.	Stock	Price
20	30	110	20	IT/807 320 0	Y	£131.58
20	50	130	20	IT/807 322 0	Y	£148.67

! Also available with 25mm diameter shank, replace the last digit with an 'H'.

SPARE PARTS

Description	T.C. Blade	
Product Ref.	IT/300 771 6/10 (B = 30)	IT/300 772 8/10 (B = 50)
Size	16x7x1.5	28x7x1.5
Price	£59.10	£65.71

Torx® Screw	Torx® Key
IT/193 400 0	IT/194 110 0
M3x4	T9
£1.67	£2.09

KEY

Spare Blades & Scorers - Product Reference ending in /10 are sold in packs of ten.

Stock - Y means normally kept in stock for next day delivery.

N means not normally held in stock, delivery in a short time.

DISPOSABLE INSERT UP & DOWN SHEAR ROUTER CUTTERS - TWO FLUTE

- Shear flutes ensure a good finish on the top and bottom of laminated and veneered board.
- Suitable for softwood, hardwood and man-made board.
- Replaceable inserts ensure a constant cutting diameter and finish quality.
- Recommended RPM (n): 18,000.

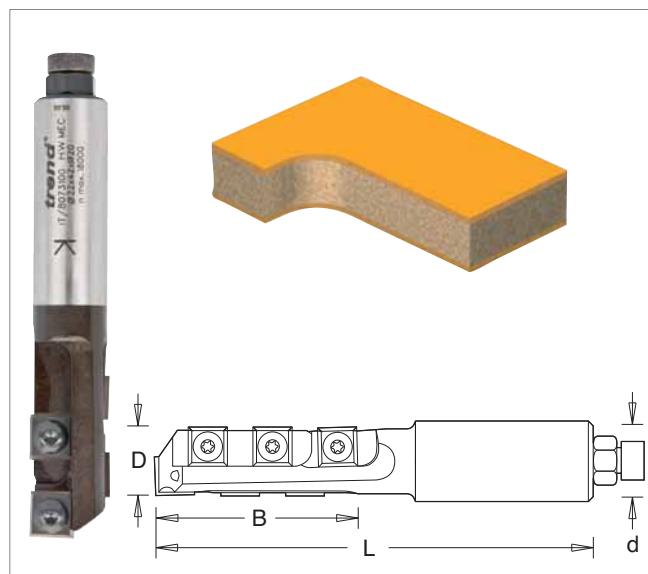

øD	B	L	ød	Product Ref.	Stock	Price
22	42	115	20	IT/807 310 0	Y	£150.35
22	62	135	20	IT/807 315 0	Y	£161.36

! Also available with 25mm diameter shank, replace the last digit with an 'H'.

SPARE PARTS

Description	T.C. Blade	Torx® Screw	Torx® Key
Product Ref.	IT/310 121 2/10	IT/193 395 0	IT/194 101 5
Size	12x12x1.5	M4x6	T15
Price	£32.92	£1.62	£3.14

SOLID CARBIDE LOCK CASING SPIRALS - THREE FLUTE

- Suitable for producing deep grooves, slots and holes for door furniture in softwood, hardwood, solid and hollow board doors.
- **RAMIB** Carbide for maximum durability in abrasive material.
- For use on routers and machining centres with CNC control.
- Recommended RPM (n): 18,000.

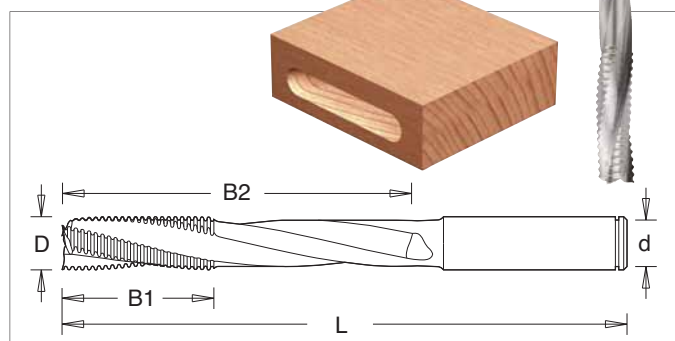

øD	B1	B2	L	ød	Product Ref.	Stock	Price
14	45	95	150	14	IT/178 640 0	Y	£265.87
16	45	115	170	16	IT/178 646 0	Y	£299.01
18	45	115	170	18	IT/178 652 0	Y	£358.85