

SOLID CARBIDE UP & DOWN COMPRESSION SPIRALS - ONE FLUTE

- Compression spiral ensures a good finish on the top and bottom of the material.
- Suitable for both softwood and hardwood.
- **NAMIC** Carbide for maximum durability in abrasive material.
- For use on routers and machining centres with CNC control.

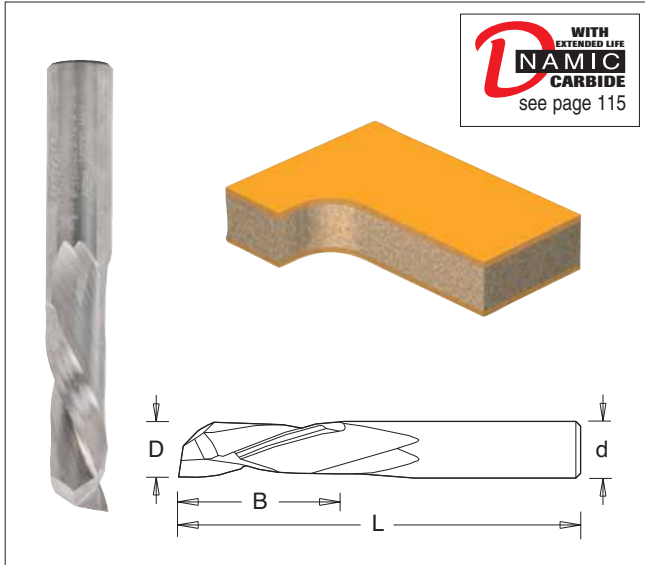

øD	B	L	ød	Product Ref.	Stock	Price
6	20	60	6	IT/174 220 3S	Y	£44.67
8	25	70	8	IT/174 227 5	Y	£50.99
10	32	80	10	IT/174 233 7	Y	£67.62
12	32	80	12	IT/174 235 9S	Y	£91.18

SOLID CARBIDE UP & DOWN COMPRESSION SPIRALS - TWO FLUTE

- Compression spiral ensures a good finish on the top and bottom of laminated and veneered board.
- Suitable for softwood, hardwood and man-made board.
- **NAMIC** Carbide for maximum durability in abrasive material.
- For use on routers and machining centres with CNC control.

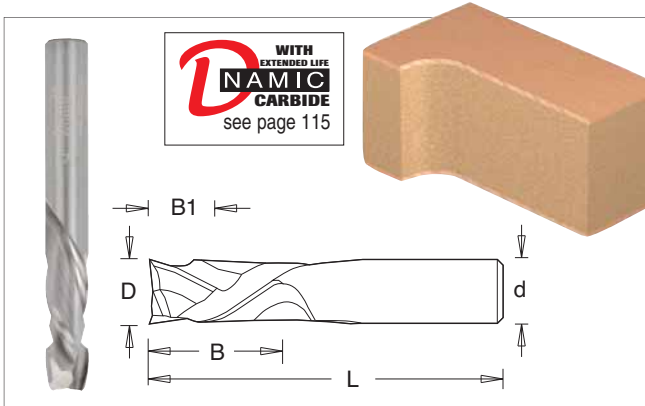

øD	B	B1	L	ød	Product Ref.	Stock	Price
3.2	21	6	63.5	3.2	IT/174 107 Z*	Y	£50.73
6	20	6	60	6	IT/174 320 3	Y	£44.67
8	25	7	70	8	IT/174 327 5	Y	£54.87
10	32	8	80	10	IT/174 333 7	Y	£74.65
12	32	8	80	12	IT/174 335 9	Y	£91.78
12	42	13	90	12	IT/174 337 9	Y	£100.76
16	52	14	110	16	IT/174 348 0	Y	£212.93
20	52	17	120	20	IT/174 356 0	Y	£365.90
20	72	20	135	20	IT/174 358 0	Y	£465.93

*Reduction bush required. 3.2mm to 1/4" IT/1927124 £17.86

SOLID CARBIDE UP & DOWN COMPRESSION SPIRALS FOR NESTING - THREE FLUTE

- Solid Carbide router cutter complete with three up and three down compression spiral flutes.
- Compression spiral ensures a good finish on the top and bottom of laminated and veneered board.
- Special high clearance geometric shape especially designed for nesting applications in coated and un-coated man-made board.
- **NAMIC** Carbide for maximum durability in abrasive material.
- For use on routers and machining centres with CNC control.
- Recommended RPM (n): 24,000.

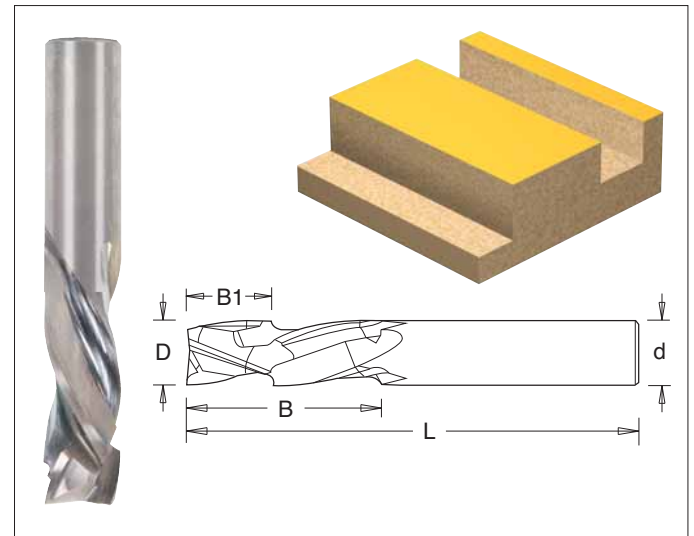

øD	B	B1	L	ød	Product Ref.	Stock	Price
8	20	5	70	8	IT/174 840 5	Y	£62.12
10	25	7	70	10	IT/174 850 7	Y	£85.93
12	32	9	80	12	IT/174 860 9	Y	£105.60

Recommended Feed for 24,000 RPM

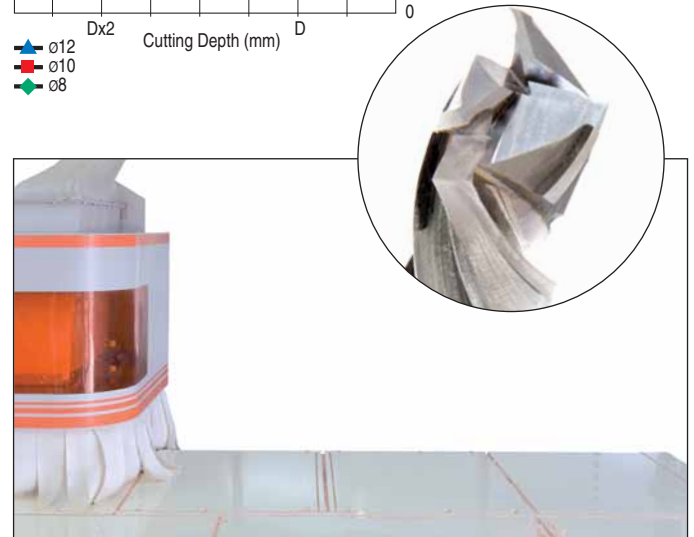
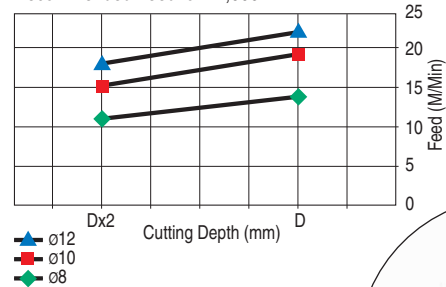

KEY

Stock - Y means normally kept in stock for next day delivery.
N means not normally held in stock, delivery in a short time.