

SOLID CARBIDE ROUGHING SPIRALS - THREE FLUTE

- Suitable for 'roughing' cuts in softwood, hardwood and man-made board (with or without coating).
- **DYNAMIC** Carbide for maximum durability in abrasive material.
- Up-cut spiral for optimum chip flow and improved finish on bottom of board.
- Down-cut for better clamping when machining small workpieces and improved finish on the top of the material.
- For use on routers and machining centres with CNC control.

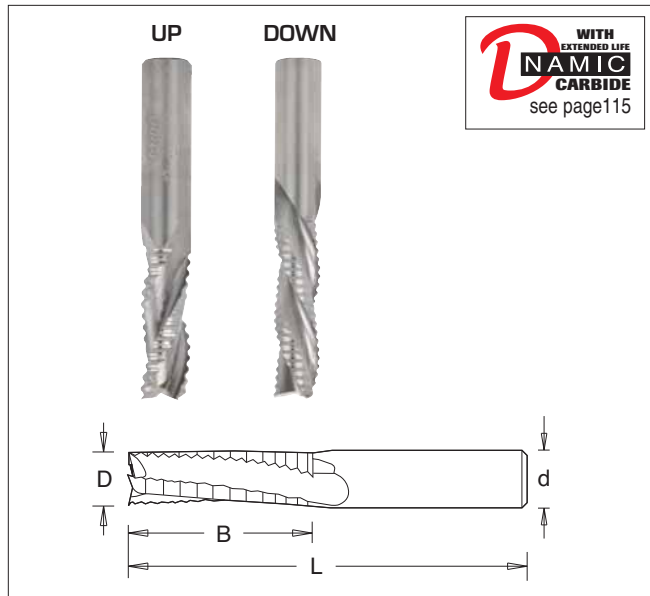

UP-CUT

øD	B	L	ød	Product Ref.	Stock	Price
10	32	80	10	IT/178 632 7	Y	£110.35
12	32	80	12	IT/178 635 9	Y	£116.65
12	52	100	12	IT/178 638 9	Y	£136.46
14	52	100	14	IT/178 641 0	Y	£173.35
16	55	110	16	IT/178 647 0	Y	£212.93
20	55	120	20	IT/178 656 0	Y	£266.48
20	72	135	20	IT/178 658 0	Y	£326.31

DOWN-CUT

øD	B	L	ød	Product Ref.	Stock	Price
10	32	80	10	IT/178 932 7	Y	£110.35
12	32	80	12	IT/178 935 9	Y	£116.65
12	52	100	12	IT/178 938 9	Y	£136.46
16	55	110	16	IT/178 947 0	Y	£212.93

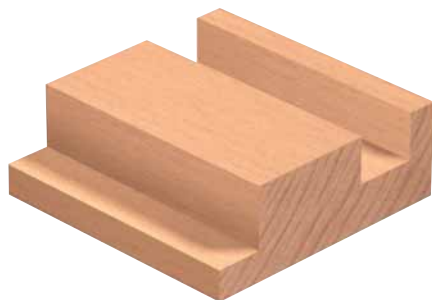

KEY

Spare Blades & Scorers - Product Reference ending in /10 are sold in packs of ten.

Stock - Y means normally kept in stock for next day delivery.

N means not normally held in stock, delivery in a short time.

DISPOSABLE INSERT ROUGH REBATING ROUTER CUTTERS - FOUR FLUTE

- Suitable for rough rebating and sizing in softwood, hardwood and man-made board (with or without coating).
- Multiple cutting flutes ensure fine chips are produced for improved waste extraction.
- Replaceable inserts ensure a constant cutting diameter.
- For use on routers and machining centres with CNC control.
- Recommended RPM (n): 18,000.

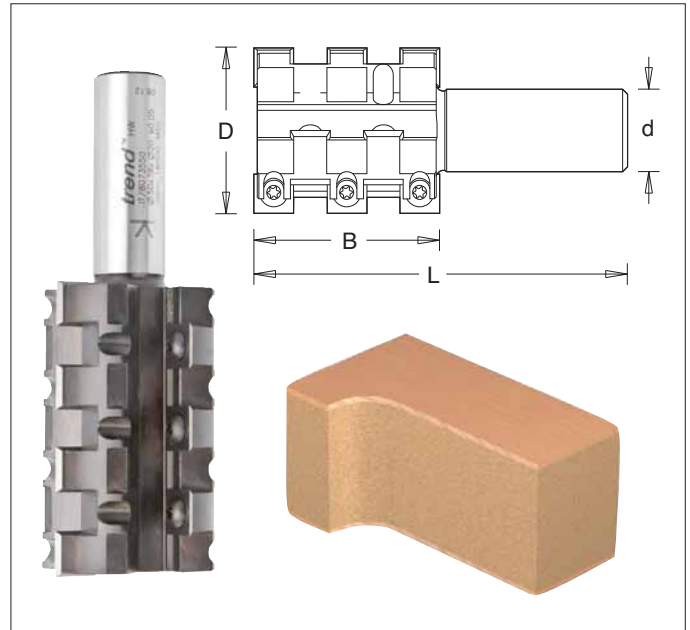

øD	B	L	ød	Product Ref.	Stock	Price
50	56	113	20x55	IT/807 350 0	Y	£198.16
50	78	135	20x55	IT/807 355 0	Y	£221.86

SPARE PARTS

Description	T.C. Blade	Torx® Screw	Torx® Key
Product Ref.	IT/310 121 2/10	IT/193 148 2	IT/194 101 5
Size	12x12x1.5	M4x5.6	T15
Price	£32.92	£1.16	£3.14