

## MULTI PROFILE CUTTER BLOCKS 60/80X5.5MM

- Hard wearing steel body complete with two tool steel rebate knives and limiter plates.
- Suitable for jointing, rebating and profiling with 5.5mm thick knives and limiters in un-bonded softwood and hardwood boards on a spindle moulder.
- Cutter block will take both 60mm and 80mm knives and limiters.
- Recommended RPM (n): 4,000 – 5,800.
- Suitable for Hand Feeding (MAN).

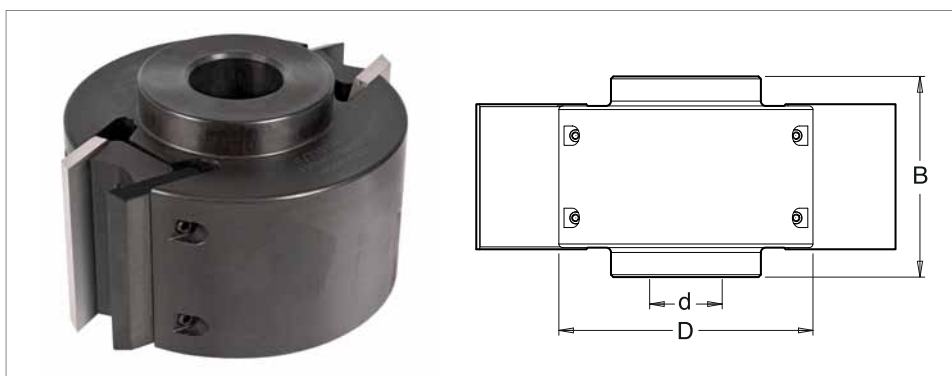
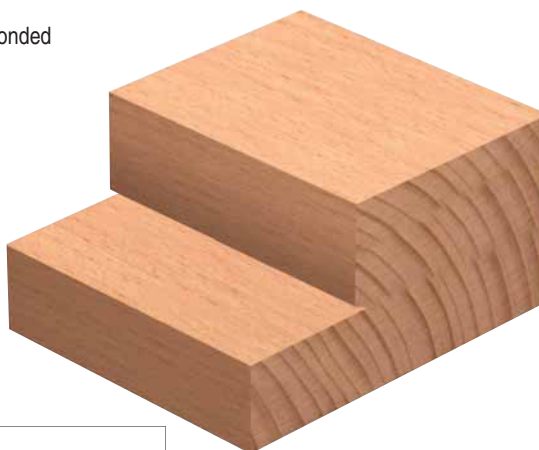

D	B	z	30mm Bore d	1 1/4" Bore d	Stock	Price
110	60/80	2	IT/710 136 1	IT/710 136 7	Y	£165.55

### KEY

**Stock** - Y means normally kept in stock for next day delivery.  
 N means not normally held in stock, delivery in a short time.

## TOOL STEEL MULTI PROFILE CUTTERS - 60X5.5MM

All drawings are actual size

Not normally held in stock, delivery in a short time.

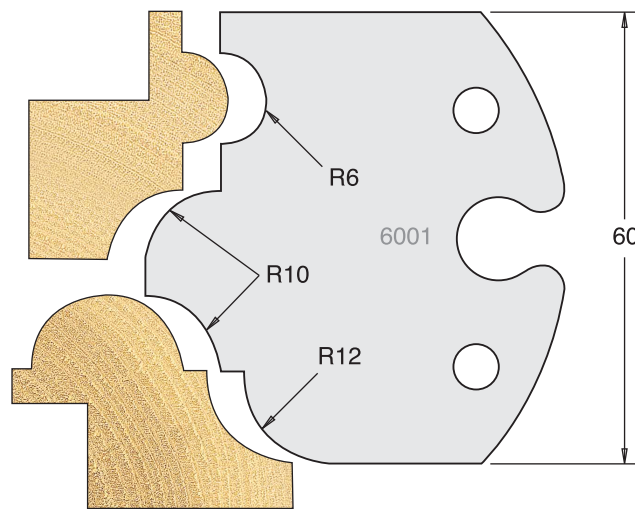
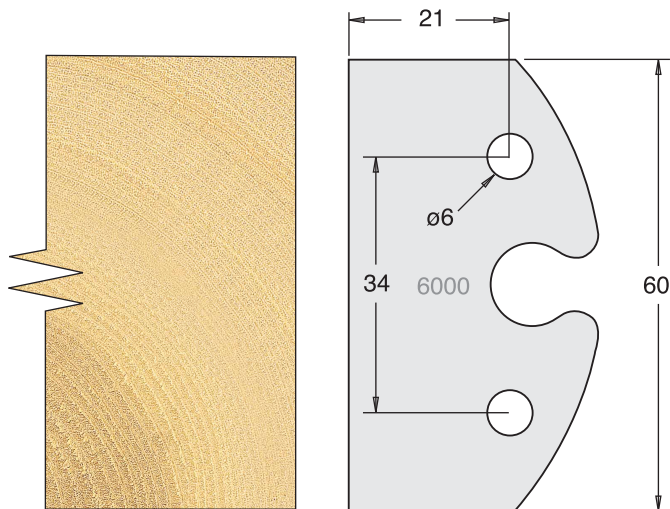

Knives	IT/33 000 60	£23.98
Limitors	IT/34 000 60	£25.50

Knives	IT/33 001 60	£31.28
Limitors	IT/34 001 60	£25.50

All blades sold as a pair  
 All prices are exclusive of VAT