

## MULTI PROFILE PANEL RAISING CUTTER BLOCK

- Hard wearing alloy body only. Knives and limitors are purchased separately.
- Suitable for producing various raised panel profiles in softwood and hardwood boards on a spindle moulder.
- The cutter block works over the top of the timber for panel raising.
- Each knife will also produce a 45° chamfer with the timber running over the top of the knife.
- All of the tool steel knives and corresponding limitor plates (1 – 7) can be used in the same block.
- Recommended RPM (n): 4,500 – 7,000.
- Suitable for Hand Feeding (MAN).

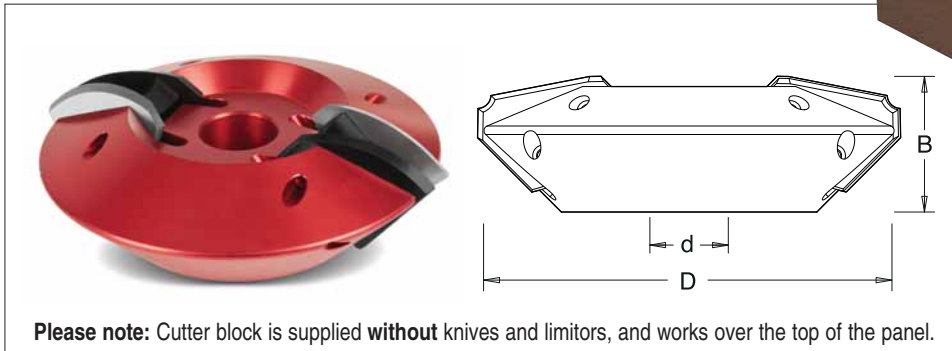
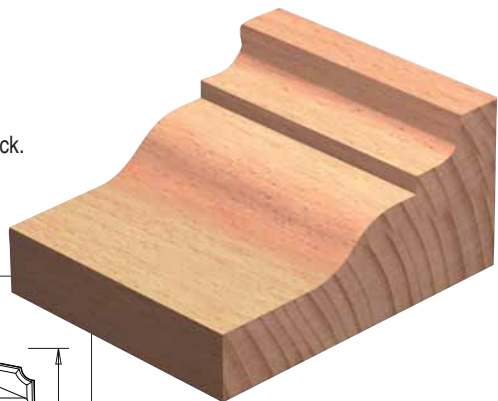

**Please note:** Cutter block is supplied **without** knives and limitors, and works over the top of the panel.

D	B	z	30mm Bore d	1 1/4" Bore d	Stock	Price
160	48	2	IT/778 101 1	IT/778 101 7	Y	£153.41

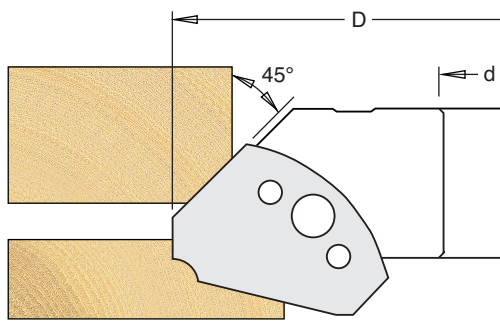
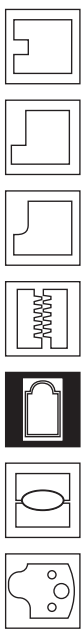

## PANEL RAISING TOOL STEEL KNIVES

- Panel raising tool steel knives and corresponding limitor plates (700 - 701) to suit cutter block IT/778 101 1 and IT/778 101 7.

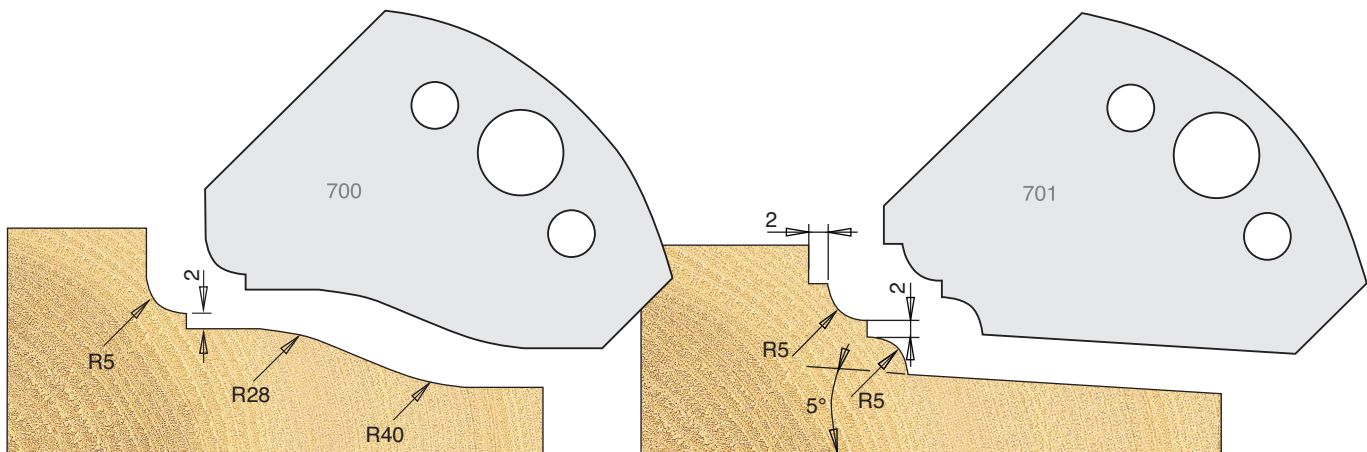

<b>Tool Steel Knives</b>	IT/33 700 40	£26.48
<b>HSS Knives</b>	IT/33 700 43	£60.71
<b>Limitors</b>	IT/34 700 40	£20.98

<b>Tool Steel Knives</b>	IT/33 701 40	£26.48
<b>HSS Knives</b>	IT/33 701 43	£60.71
<b>Limitors</b>	IT/34 701 40	£20.98

### KEY

**Stock** - Y means normally kept in stock for next day delivery.  
 N means not normally held in stock, delivery in a short time.

All knives and limitor plates sold as a pair

All prices are exclusive of VAT