

DISPOSABLE INSERT GLUE JOINT CUTTER BLOCKS

- Hard wearing steel and alloy body complete with disposable Tungsten Carbide knives (z).
- Suitable for producing "finger style" reversible glue joints in softwood and hardwood on a spindle moulder.
- Recommended RPM (n): 120mm diameter 6,500 – 9,500. 140mm diameter 5,400 – 8,800.
- Suitable for Hand Feeding (MAN).

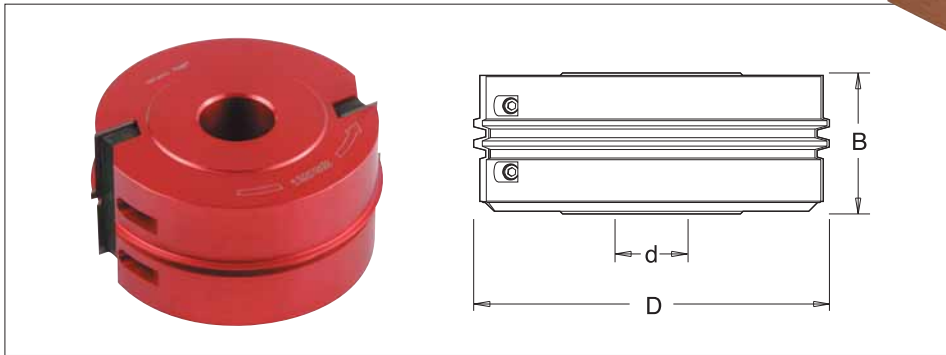
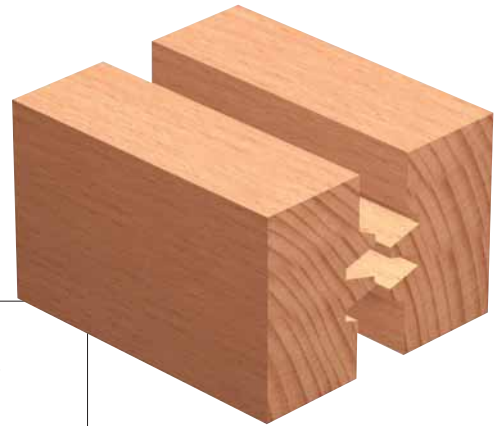

D	Profile	z	B	30mm Bore d	1 1/4" Bore d	Stock	Price
120	A	2	60	IT/741 004 1*	IT/741 004 7*	N	£233.15
140	B	2	50	IT/741 006 1	IT/741 006 7	Y	£251.93
140	C	2	60	IT/741 005 1	IT/741 005 7	Y	£278.01

* Hard wearing alloy body.

SPARE KNIVES

Description	T.C. Blade		
Product Ref.	IT/310 855 1	IT/310 855 2	IT/310 850 1
Size	60x24x2 1 tooth	50x24x2 2 teeth	60x24x2 3 teeth
Price	£46.36	£48.56	£54.08

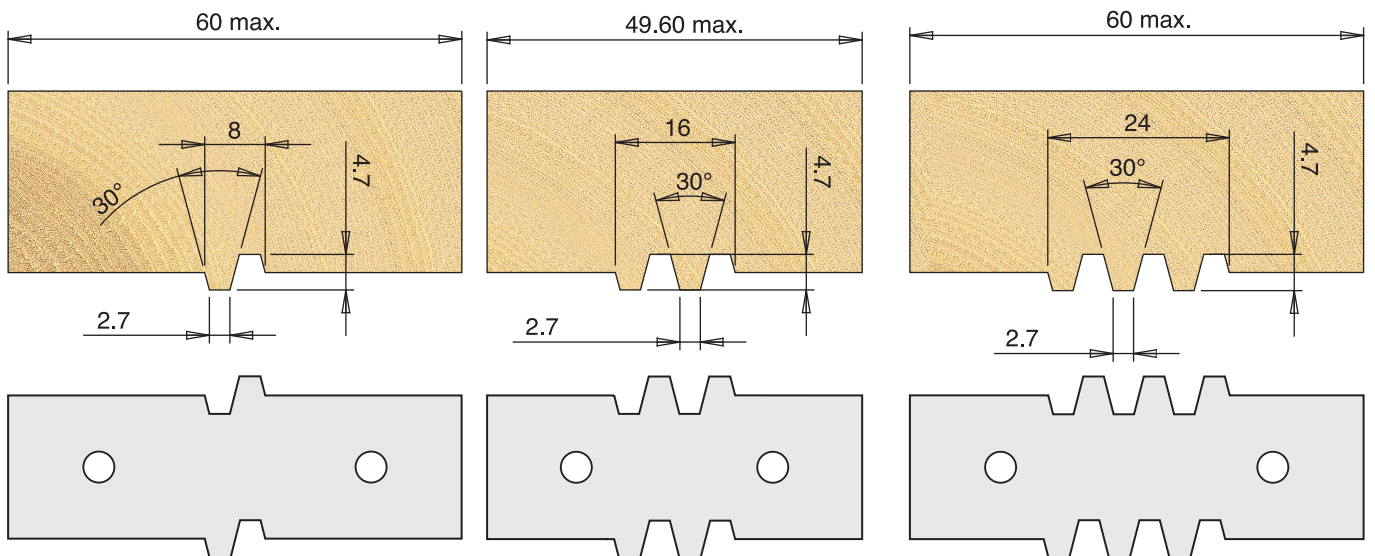

PROFILE A

Scale 1:1

PROFILE B

PROFILE C

KEY

Spare Knives and Scorers - Product Reference ending in /10 are sold in packs of ten.

Stock - Y means normally kept in stock for next day delivery.

N means not normally held in stock, delivery in a short time.