

DISPOSABLE INSERT MULTI ROUND OVER CUTTER BLOCKS

- Hard wearing alloy body complete with disposable Tungsten Carbide knives (z).
- Suitable for producing various radii in softwood, hardwood and man-made boards on a spindle moulder.
- Different radii can be achieved by adjusting the height of the spindle shaft.
- Recommended RPM (n) 140mm diameter 5,400 – 8,800. 180mm diameter 4,500 – 7,500.
- Suitable for Hand Feeding (MAN).

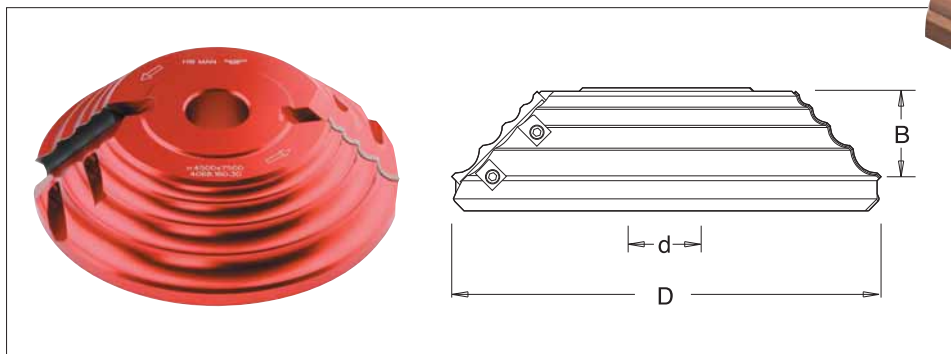
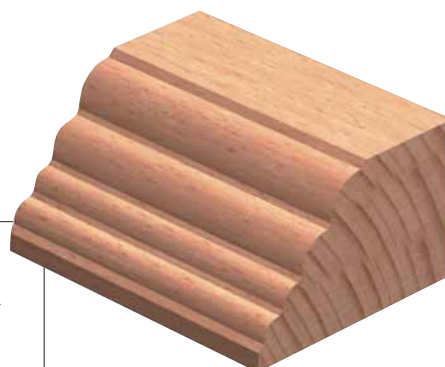

D	R	z	B	30mm Bore d	1 1/4" Bore d	Stock	Price
140	2,3,5	2	25	IT/752 109 1	IT/752 109 7	Y	£167.44
180	4,6,8,10	2	50	IT/752 110 1	IT/752 110 7	Y	£198.74

SPARE KNIVES

Description	T.C. Blade	
Product Ref.	IT/310 855 0	IT/310 854 9
Size	R=2,3,5	R=4,6,8,10
Price	£26.48	£39.74

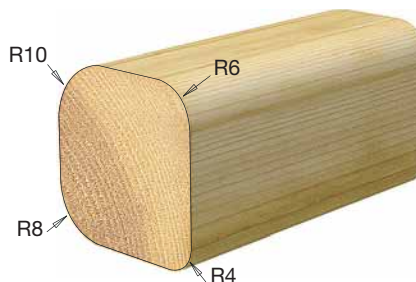

Different radii that can be produced with block IT/752 110 1 (7).

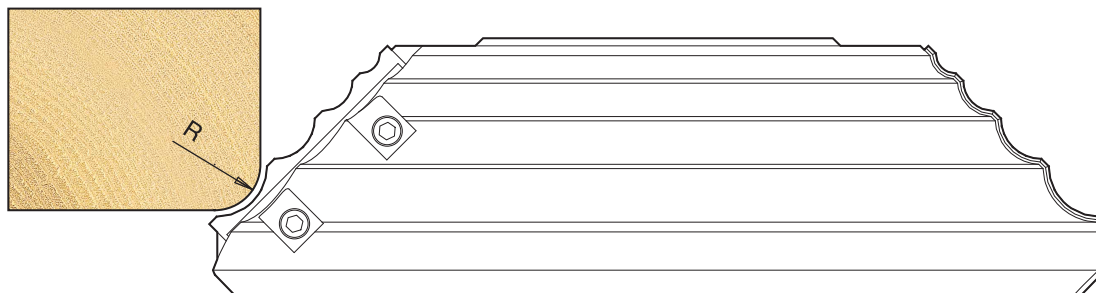

KEY

Spare Knives and Scorers - Product Reference ending in /10 are sold in packs of ten.

Stock - Y means normally kept in stock for next day delivery.

N means not normally held in stock, delivery in a short time.