

DISPOSABLE INSERT BEADING CUTTER BLOCKS

- Hard wearing alloy body complete with disposable Tungsten Carbide knives (z).
- Suitable for producing various radii beads in softwood, hardwood and man-made boards on a spindle moulder.
- R3 and R4 knives will fit in the same block. R5 and R6 knives will fit in the same block. R8 and R10 knives will fit in the same block.
- Can be used with a 110mm diameter ball bearing guide ring for ring fence work. See page 91.
- Recommended RPM (n) 125mm diameter 6,000 – 10,000. 135mm diameter 5,500 – 9,000.
- Suitable for Hand Feeding (MAN).

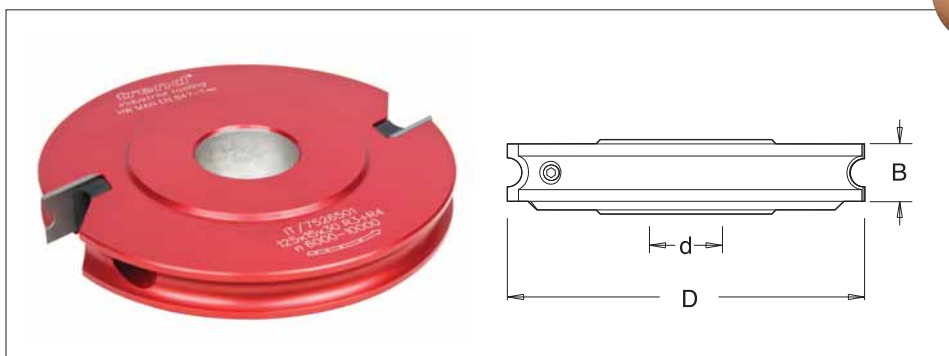
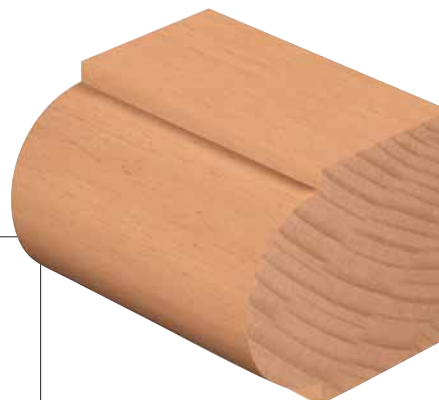

D	R	z	B	30mm Bore d	Stock	1 1/4" Bore d	Stock	Price
125	3	2	15	IT/752 603 1	N	IT/752 603 7	N	£137.21
125	4	2	15	IT/752 604 1	Y	IT/752 604 7	N	£137.21
125	5	2	20	IT/752 605 1	N	IT/752 605 7	N	£147.05
125	6	2	20	IT/752 606 1	N	IT/752 606 7	N	£147.05
125	8	2	30	IT/752 608 1	N	IT/752 608 7	N	£169.55
125	10	2	30	IT/752 610 1	N	IT/752 610 7	Y	£169.55
125	12	2	30	IT/752 612 1	N	IT/752 612 7	N	£169.55
125	15	2	40	IT/752 615 1	N	IT/752 615 7	N	£185.65
135	20	2	50	IT/752 620 1	N	IT/752 620 7	N	£197.69

SPARE KNIVES

Description	T.C. Blade								
	R=3	R=4	R=5	R=6	R=8	R=10	R=12	R=15	R=20
Product Ref.	IT/312 400 3	IT/312 400 4	IT/312 400 5	IT/312 400 6	IT/312 400 8	IT/312 401 0	IT/312 401 2	IT/312 401 5	IT/312 402 0
Price	£13.25	£13.25	£14.35	£14.35	£26.48	£29.81	£30.91	£43.05	£45.22

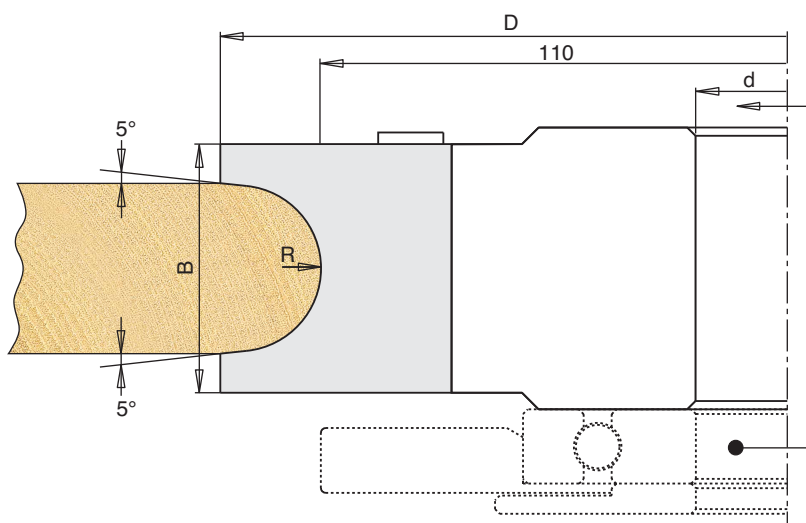

KEY

Spare Knives and Scorers - Product Reference ending in /10 are sold in packs of ten.

Stock - Y means normally kept in stock for next day delivery.

N means not normally held in stock, delivery in a short time.