

## DISPOSABLE INSERT ROUNDING OVER CUTTER BLOCK SET

- Hard wearing steel body complete with disposable Tungsten Carbide knives (z).
- Suitable for rounding over one side or both sides of softwood, hardwood and man-made boards on a spindle moulder.
- Cutter block supplied as standard with R3 knives, body will accept R1 to R10 knives.
- IT/752 033 1/7 is two part construction, IT/752 030 1/7 is three part construction.
- Recommended RPM (n) 4,500 – 7,500.
- Suitable for Hand Feeding (MAN).

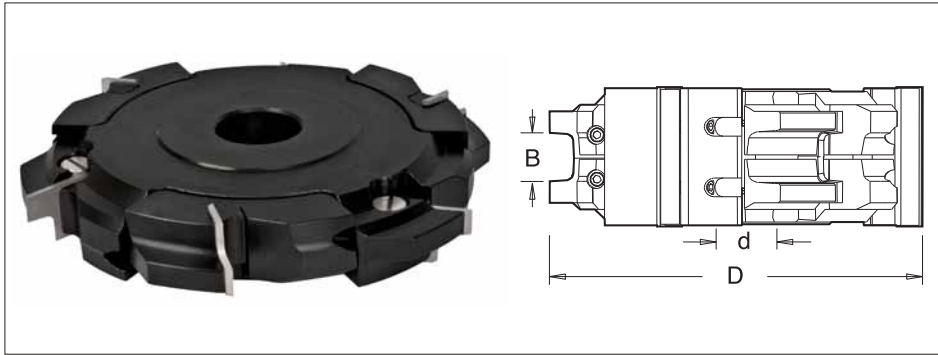
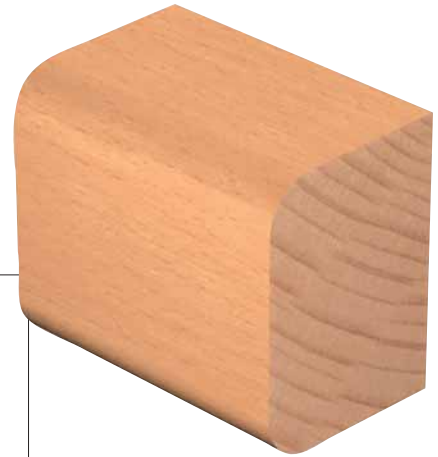

D	B	z	Set	30mm Bore d	1 1/4" Bore d	Stock	Price
170	6.0 - 20.0	3+3	1	IT/752 033 1	IT/752 033 7	N	£550.72
170	20.0 - 60.0	3+3+3	2	IT/752 030 1	IT/752 030 7	N	£705.22

### SPARE KNIVES\*

	T.C. Blade RH	T.C. Blade LH
R=1	IT/310 890 1	IT/310 890 1L
	20x25x2 £19.36	20x25x2 £19.36
R=2	IT/310 890 2	IT/310 890 2L
	20x25x2 £19.36	20x25x2 £19.36
R=3	IT/310 890 3	IT/310 890 3L
	20x25x2 £19.36	20x25x2 £19.36
R=4	IT/310 890 4	IT/310 890 4L
	20x25x2 £19.36	20x25x2 £19.36
R=5	IT/310 890 5	IT/310 890 5L
	20x25x2 £19.36	20x25x2 £19.36
R=6	IT/310 890 6	IT/310 890 6L
	20x25x2 £19.36	20x25x2 £19.36
R=7	IT/310 890 7	IT/310 890 7L
	20x25x2 £19.36	20x25x2 £19.36
R=8	IT/310 890 8	IT/310 890 8L
	20x25x2 £19.36	20x25x2 £19.36
R=9	IT/310 890 9	IT/310 890 9L
	20x25x2 £19.36	20x25x2 £19.36
R=10	IT/310 891 0	IT/310 891 0L
	20x25x2 £22.48	20x25x2 £22.48

#### SET 1 - Two Parts

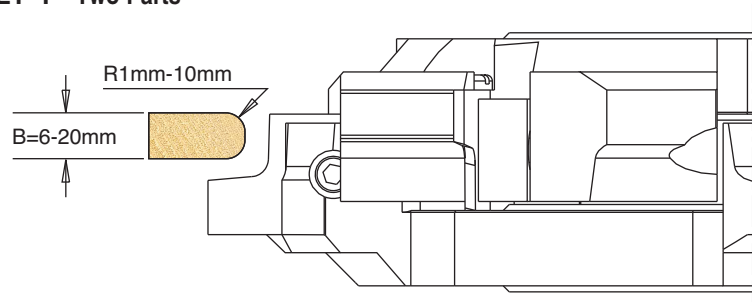

#### SET 2 - Three Parts

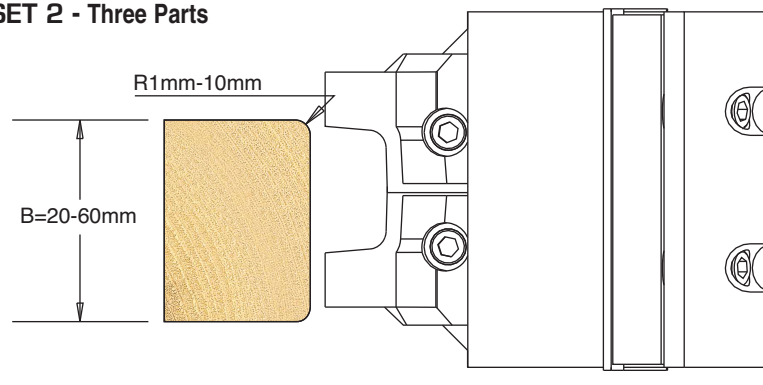

\* Three RH and three LH knives are required for each radius produced.

#### KEY

**Spare Knives and Scorers** - Product Reference ending in /10 are sold in packs of ten.

**Stock** - Y means normally kept in stock for next day delivery.

N means not normally held in stock, delivery in a short time.