

DISPOSABLE INSERT ADJUSTABLE CHAMFER CUTTER BLOCKS

- Hard wearing alloy body complete with disposable Tungsten Carbide knives (z).
- Suitable for producing chamfer cuts at various angles in softwood, hardwood and man-made boards on a spindle moulder.
- Cutting angle can be adjusted in 1° steps by using the special geared mechanism.
- Can also be used as a panel raising block.
- Recommended RPM (n) 160mm diameter 4,800 – 6,000. 170mm diameter 4,500 – 6,000.
- Suitable for Hand Feeding (MAN).

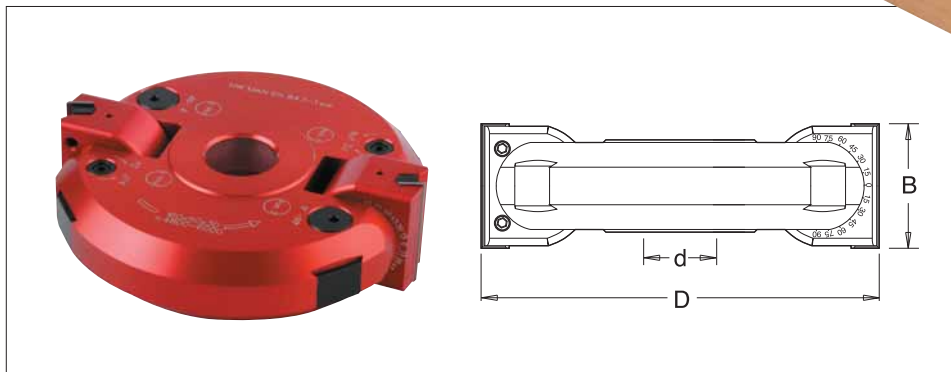
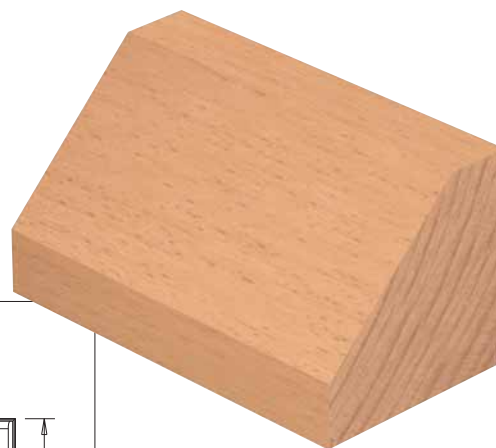

D	B	z	angle	30mm Bore d	1 1/4" Bore d	Stock	Price
160	50	2	-90° to +90°	IT/734 030 1	IT/734 030 7	Y	£387.52
170	60	2	-90° to +90°	IT/734 035 1	IT/734 035 7	Y	£400.49

SPARE KNIVES

Description	T.C. Blade	
Product Ref.	IT/310 125 0/10	IT/300 053 1/10
Size	50x12x1.5 B=50mm	60x12x1.5 B=60mm
Price	£33.96	£56.32

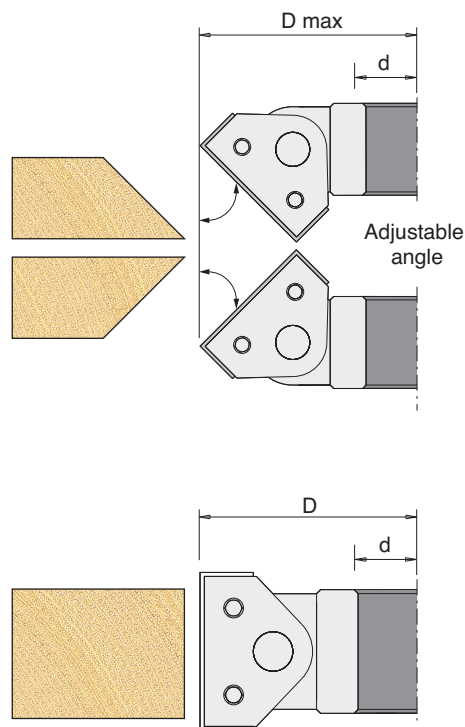
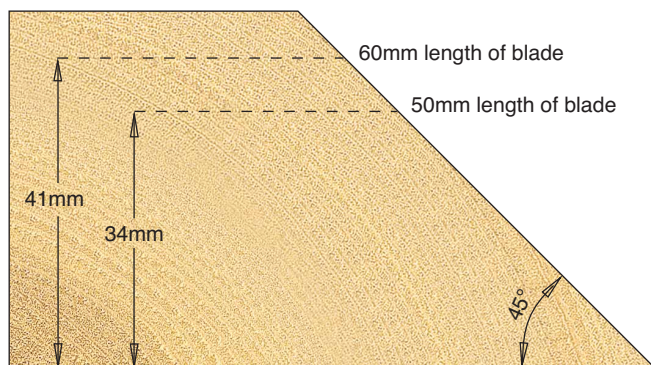

KEY

Spare Knives and Scorers - Product Reference ending in /10 are sold in packs of ten.

Stock - Y means normally kept in stock for next day delivery.

N means not normally held in stock, delivery in a short time.