

DISPOSABLE INSERT ADJUSTABLE CHAMFER CUTTER BLOCKS

- Hard wearing steel and alloy body complete with disposable Tungsten Carbide knives (z).
- Suitable for producing chamfer cuts at various angles in softwood, hardwood and man-made boards on a spindle moulder.
- Cutting angle can be adjusted in 7.5° steps by using the notched scale. Fine adjustment of 1° is also possible.
- Recommended RPM (n) 110mm diameter 7,000 – 9,000. 120mm diameter 6,400 – 8,500. 130mm diameter 5,000 – 8,500. 150mm diameter 5,100 – 7,400.
- Suitable for Hand Feeding (MAN).

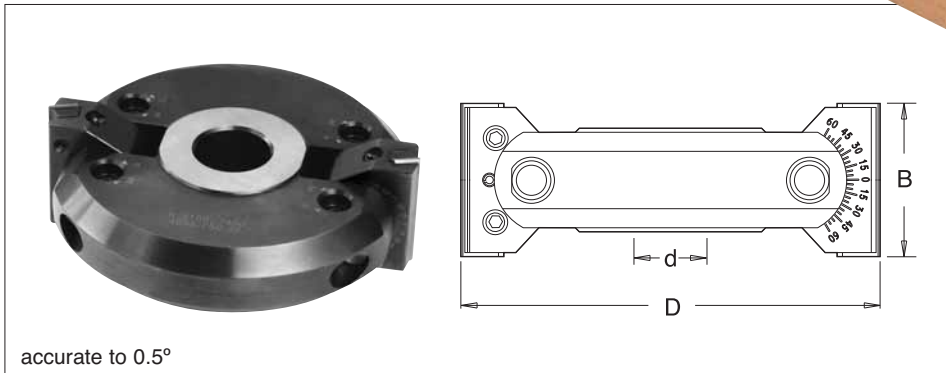

accurate to 0.5°

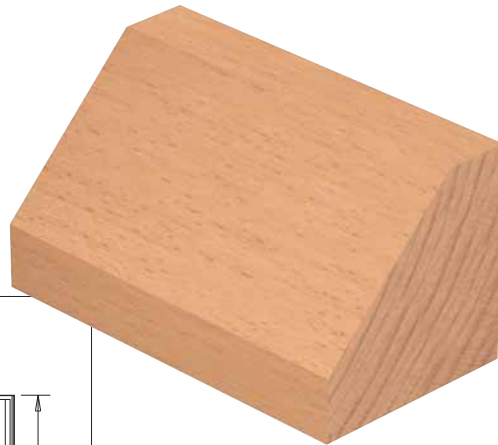

D	B	z	angle	30mm Bore d	Stock	1 1/4" Bore d	Stock	Price
110	40	2	-45° to +45°	IT/734 014 1	Y	IT/734 014 7	N	£294.11
120	40	2	-45° to +45°	IT/734 015 1*	Y	IT/734 015 7*	Y	£198.74
130	50	2	-67.5° to +67.5°	IT/734 016 1	Y	IT/734 016 7	Y	£334.32
150	50	2	-90° to +90°	IT/734 017 1	Y	IT/734 017 7	Y	£347.87

* Hard wearing alloy body.

SPARE KNIVES

Description	T.C. Blade	
	Product Ref.	IT/300 052 8/10
Size	40x12x1.5 B=40mm	50x12x1.5 B=50mm
Price	£33.96	£33.96

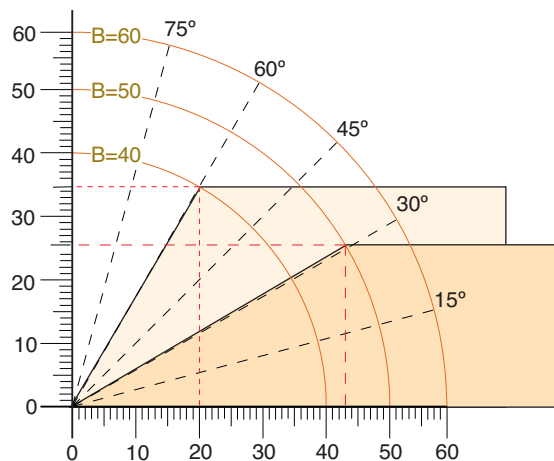
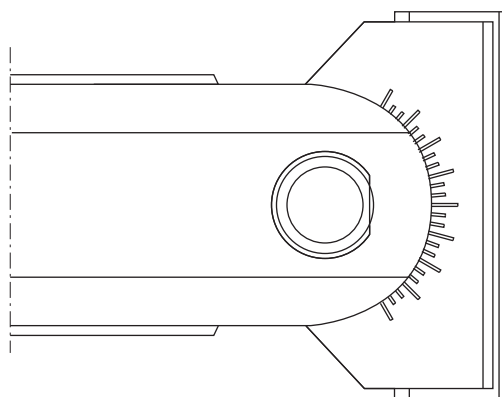

KEY

Spare Knives and Scorers - Product Reference ending in /10 are sold in packs of ten.

Stock - Y means normally kept in stock for next day delivery.

N means not normally held in stock, delivery in a short time.