

DISPOSABLE INSERT SPIRAL PLANING CUTTER BLOCK

- Hard wearing alloy body complete with disposable Tungsten Carbide knives (z).
- Suitable for rough planing and routing of softwood, hardwood and man-made boards on a spindle moulder.
- Can also be used with a ball bearing guide for template work.
- Will leave slight witness lines on the edge of the material.
- Recommended RPM (n) 8,000 – 12,000.
- Suitable for Hand Feeding (MAN).

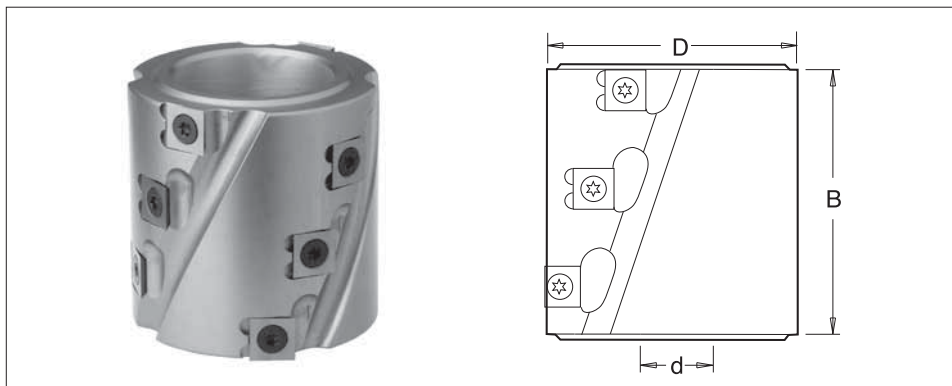
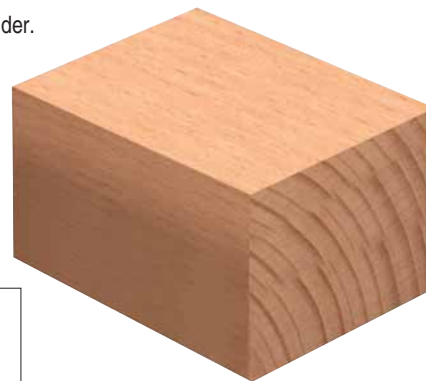

D	B	z	30mm Bore d	1 1/4" Bore d	Stock	Price
62	82	12	IT/ST/PH001	IT/ST/PH007	Y	£135.58
80	100	16	IT/ST/PH011	IT/ST/PH017	Y	£241.50

SPARE KNIVES

Description	T.C. Blade	
Product Ref.	IT/300 850 3/10	IT/ST/IB02
Size	14x14x2 B=80-100mm	14.3x14.3x2.5 IT/ST/PH017 only
Price	£22.48	£3.14

BALL BEARING GUIDE

Description	Ball Bearing	
Product Ref.	IT/B62X30	IT/B62X114
Size	62x16x30	62x15x1-1/4"
Price	£20.85	£58.99

* for details of 80mm ball bearing guide ring see page 91.

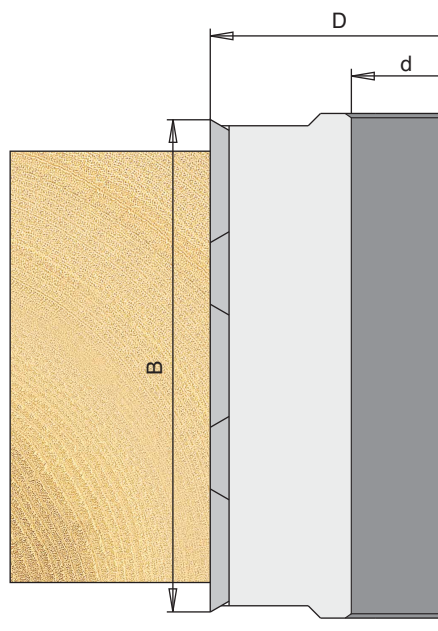

KEY

Spare Knives and Scorers - Product Reference ending in /10 are sold in packs of ten.

Stock - Y means normally kept in stock for next day delivery.

N means not normally held in stock, delivery in a short time.

