

DISPOSABLE INSERT ADJUSTABLE GROOVING & REBATING CUTTER BLOCK WITH SCORERS 20.6-100.0MM

- Hard wearing steel body complete with disposable Tungsten Carbide knives (z) and scorers (v).
- Suitable for producing various width grooves and rebates in softwood, hardwood and man-made boards on a spindle moulder.
- Cutting width can be adjusted by 0.1mm by using supplied spacer rings.
- Recommended RPM (n) 4,800 – 8,000.
- Suitable for Hand Feeding (MAN).
- 200mm diameter available to special order.

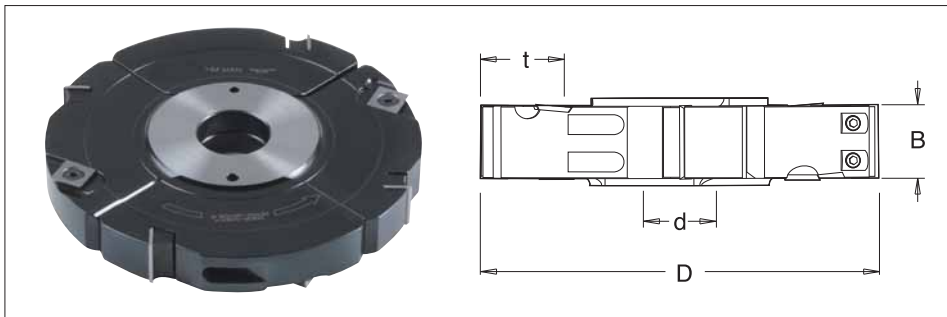
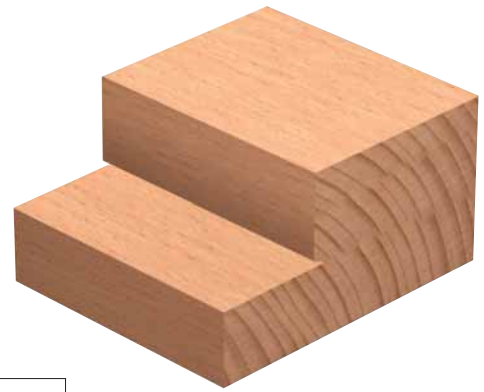

D	B	z	v	max. t	30mm Bore d	Stock	1 1/4" Bore d	Stock	Price
160	20.6 - 40.0	4	4	40	IT/722 007 1	N	IT/722 007 7	Y	£295.73
160	30.6 - 60.0	4	4	40	IT/722 032 1	Y	IT/722 032 7	N	£342.66
160	50.6 - 100.0	4	4	40	IT/722 033 1	Y	IT/722 033 7	N	£389.02

SPARE KNIVES

Description	T.C. Blade		
	Product Ref.	IT/310 122 0/10	IT/310 123 0/10
Size	20x12x1.5 B=20.6-40mm	30x12x1.5 B=30.6-60mm	50x12x1.5 B=50.6-100mm
Price	£22.48	£22.48	£33.96

SPARE SCORER

Description	T.C. Blade
Product Ref.	IT/300 850 3/10
Size	14x14x2 B=20.6-100mm
Price	£22.48

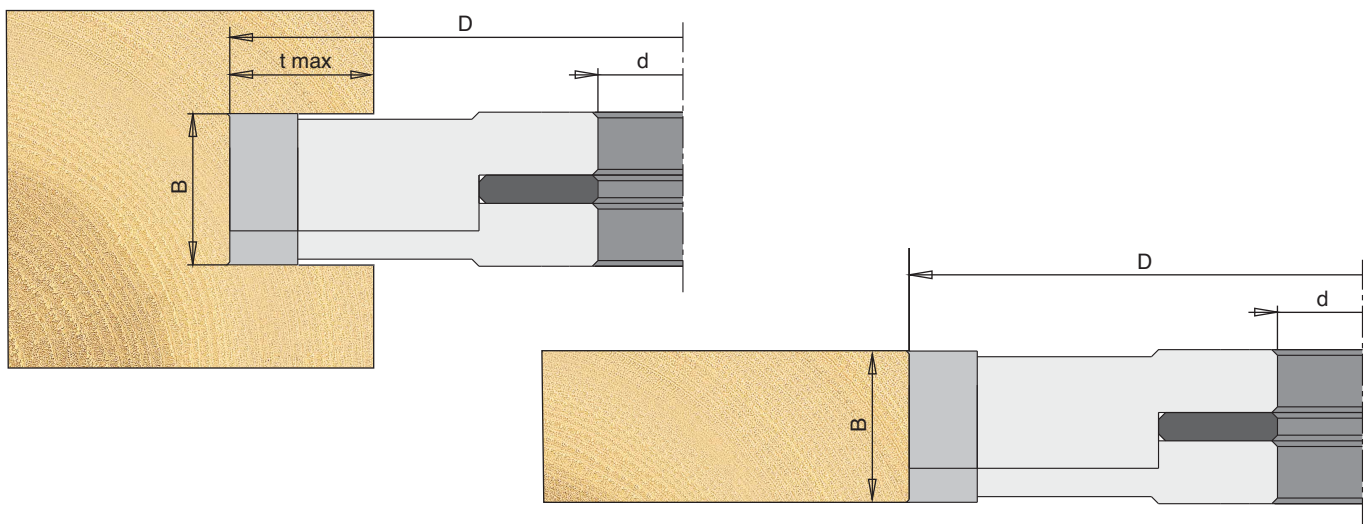

KEY

Spare Knives and Scorers - Product Reference ending in /10 are sold in packs of ten.

Stock - Y means normally kept in stock for next day delivery.

N means not normally held in stock, delivery in a short time.