

## DISPOSABLE INSERT UP & DOWN SHEAR PLANING CUTTER BLOCK

- Hard wearing alloy body complete with disposable Tungsten Carbide knives (z).
- Suitable for finish sizing board that is laminated on both top and bottom on a spindle moulder.
- Shear cutting angle on top and bottom ensures a very clean cut without chipping. Use on laminated board to clean edge after sawing and before edging.
- Cannot be used for rebating.
- Recommended RPM (n) 6,100 – 9,000.
- Suitable for Hand Feeding (MAN).

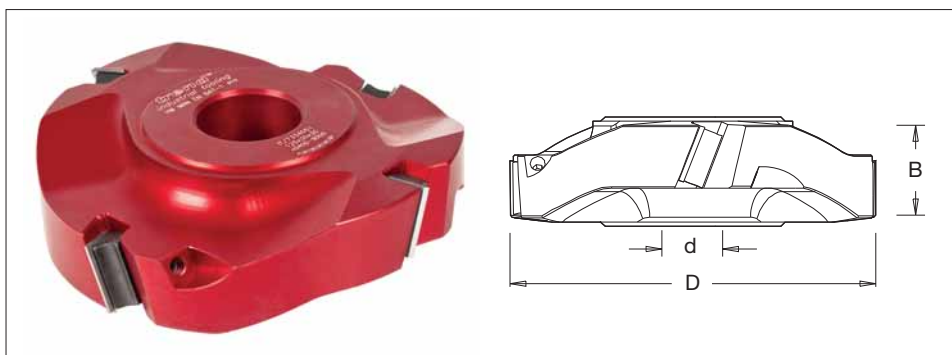
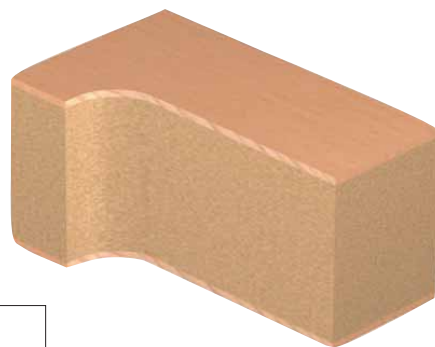

D	B	z	30mm Bore d	Stock	1 1/4" Bore d	Stock	Price
125	30	2+2	IT/733 405 1	Y	IT/733 405 7	N	£264.87

## SPARE KNIFE

Description	T.C. Blade
Product Ref.	IT/311 122 0/10
Size	20x12x1.5
Price	£49.67

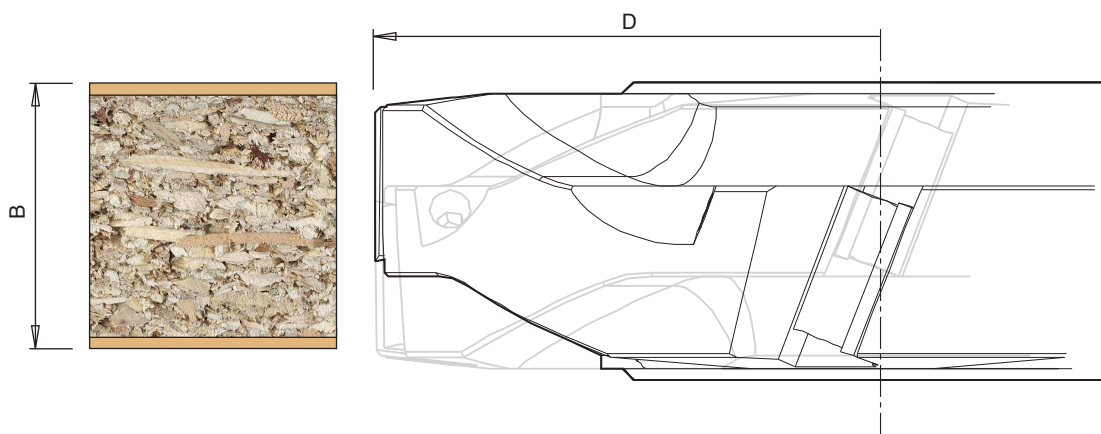

### KEY

**Spare Knives and Scorers** - Product Reference ending in /10 are sold in packs of ten.

**Stock** - Y means normally kept in stock for next day delivery.

N means not normally held in stock, delivery in a short time.

