

DISPOSABLE INSERT SHEAR REBATING CUTTER BLOCKS

- Hard wearing alloy body complete with disposable Tungsten Carbide knives (z) and scorers (v).
- Suitable for producing various thickness rebates in softwood, hardwood and man-made boards on a spindle moulder.
- Shear angle reduces tear out and improves quality of cut.
- Recommended RPM (n) 125mm diameter 6,100 – 10,300. 150mm diameter 5,200 – 8,600.
- Suitable for Hand Feeding (MAN).

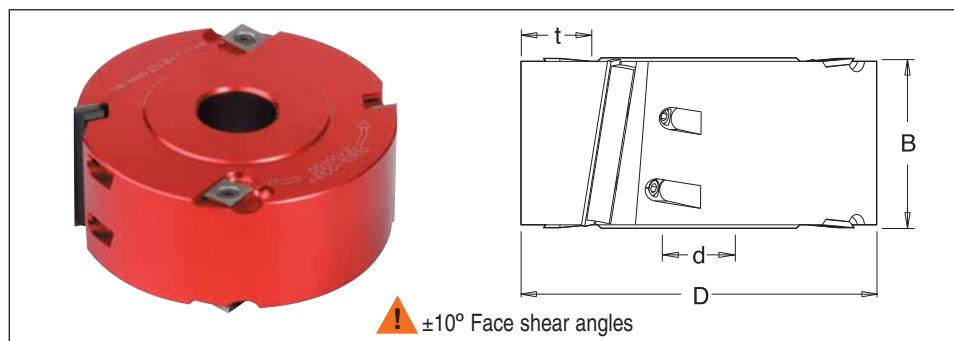
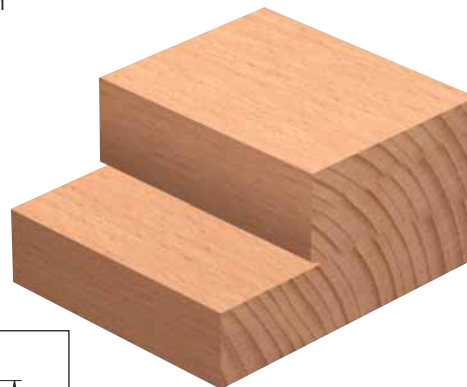

D	B	z	v	max. t	30mm Bore d	1 1/4" Bore d	Stock	Price
125	50	2	4	27	IT/733 004 1	IT/733 004 7	Y	£141.27
125	60	2	4	27	IT/733 005 1	IT/733 005 7	Y	£161.66
150	60	2	4	40	IT/733 006 1	IT/733 006 7	Y	£178.36

SPARE KNIVES

Description	T.C. Blade	
Product Ref.	IT/310 125 0/10	IT/300 053 1/10
Size	50x12x1.5 B=50mm	60x12x1.5 B=60mm
Price	£33.96	£56.32

SPARE SCORER

Description	T.C. Blade
Product Ref.	IT/300 850 3/10
Size	14x14x2 B=50-60mm
Price	£22.48

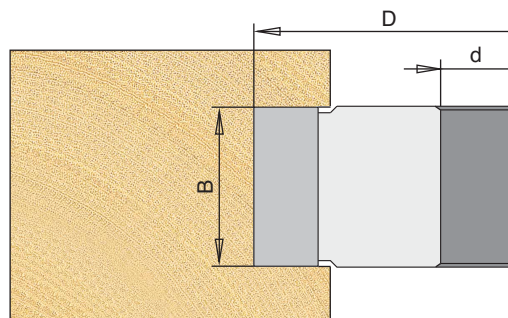
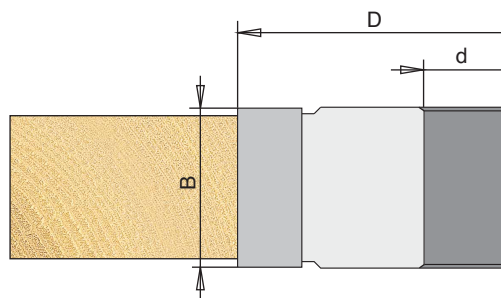

KEY

Spare Knives and Scorers - Product Reference ending in /10 are sold in packs of ten.

Stock - Y means normally kept in stock for next day delivery.

N means not normally held in stock, delivery in a short time.

